

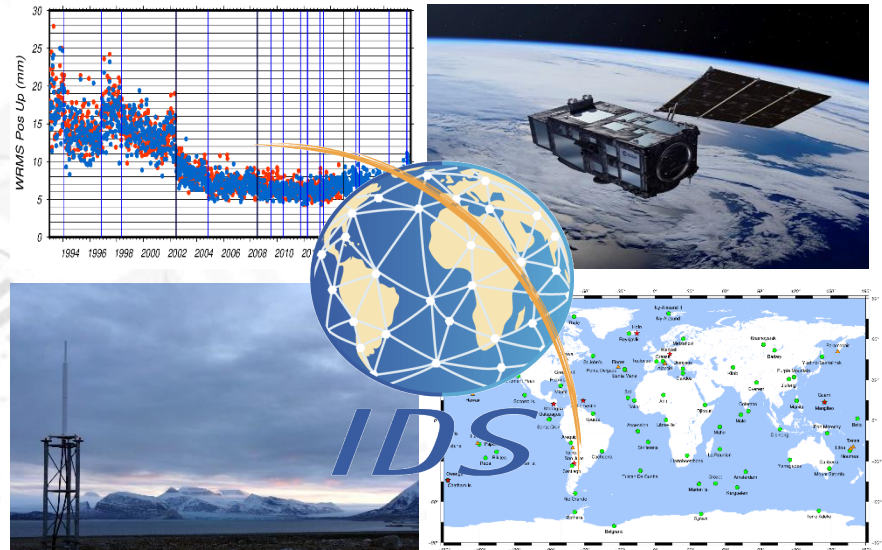

Research Activities in the International DORIS Service (IDS): Current Topics, Trends, and Results

Petr Štěpánek (GOP), Guilhem Moreaux (CLS), Susanne Blondel (CNES), Hugues Capdeville (CLS), Alexandre Couhert (CNES), Frank Lemoine (NASA), Cécile Manfredi (CNES), Arnaud Pollet (IGN), Samuel Nahmani (IGN), Jérôme Saunier (IGN), Patrick Schreiner (GFZ), Laurent Soudarin (CLS), Ningbo Wang (AIR-CAS), Julian Zeitlhöfler (DGFI-TUM), and Nikita P. Zelensky (ESSIC)





Presentation outline

- ❑ **Introduction to the DORIS system**
- ❑ **Introduction to the International DORIS Service (IDS)**
- ❑ **IDS ITRF processing**
- ❑ **Selected recent reseach topics in IDS/DORIS**
 - **Impact/mitigation of increased solar activity (GRG AC)**
 - **Impact of the South Atlantic Anomaly and mitigation through the integration of GNSS clocks for Sentinels satellites (GRG and GOP AC)**
 - **SWOT self-shadowing modeling (CNES AAC)**
 - **NRT Ionosphere applications (Working Group)**

DORIS system

- DORIS is a satellite navigation system operated by the French Space Agency (CNES) since 1990 as one of the four core IERS techniques, contributing to the creation of the ITRF and being part of GGOS.
- “Reverse” GPS – transmitters on the ground, receivers on the satellite.
- Worldwide network of ground stations – transmitters.
- Variable satellite constellation, currently 10 satellites.
- Satellites in low Earth orbit at 700–1300 km. Each satellite has specific characteristics.
- Each satellite carries a number of other instruments and devices.
- Older data type: Doppler measurements. Newer data type: phase and code measurements.

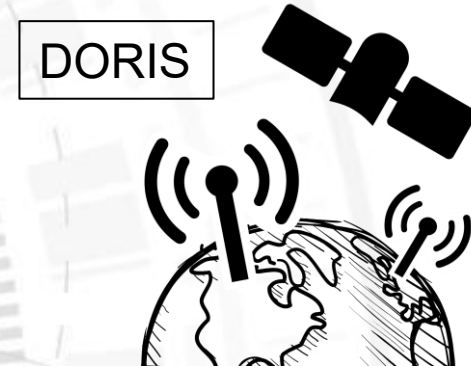

Figures by GGOS

DORIS as an integral part of GGOS

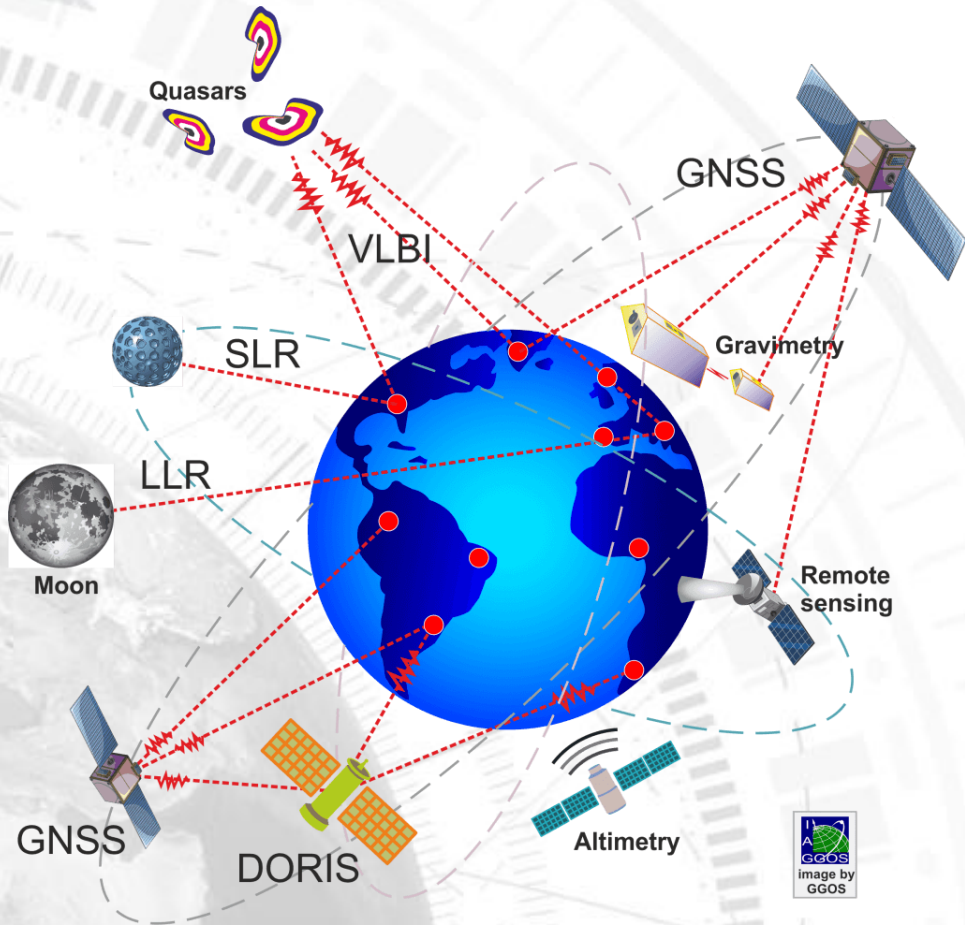

DORIS beacon

BEACON B4G

A simple gestion rack, with battery inside



Small white box : MGM module

Medium white box : deported amplifier

RF cables of 25m or 50m



Saint Helena antenna with Leclerc pillar

- ⇒ Compact configuration
- ⇒ Less cables
- ⇒ Clear field of view for the antenna

DORIS Constellation

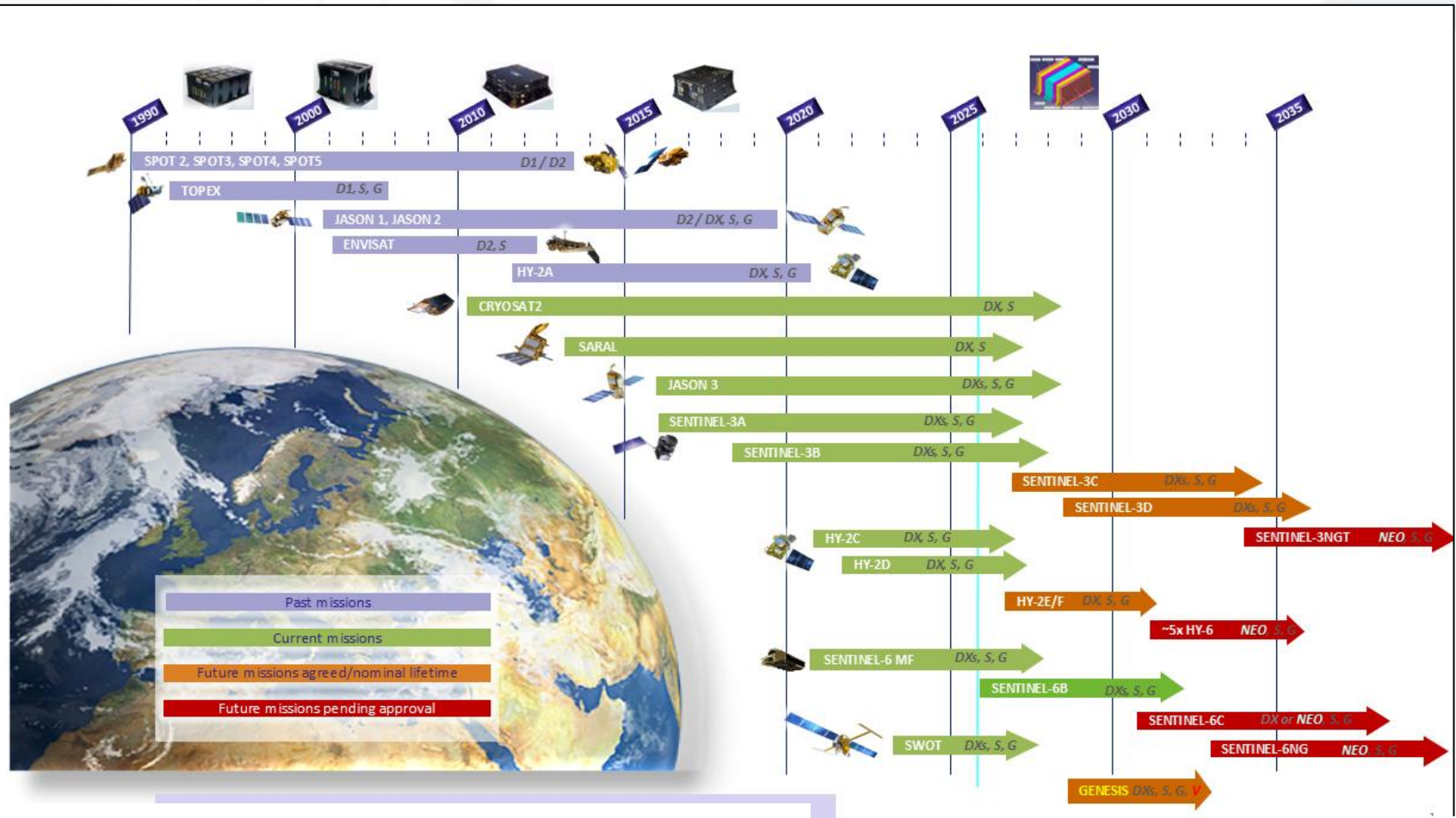

Six satellites to be launched in the next five years.
 All equipped with the latest generation of DORIS receivers enable to track seven beacons simultaneously.



The DORIS Station Network

KANPUR
INDIA



- @2026.0: 61 operational sites with 4 four-technique sites.**
- @2026.5: 63 - Kanpur (India, GNSS), Katherine (Australia, GNSS/VLBI).**
- @2027.0: 64 - Kazakhstan (Kokshetau or Karaganda, GNSS).**
- @2028.0: 65 - Gamak (South Korea, GNSS/SLR).**

International DORIS Service chart

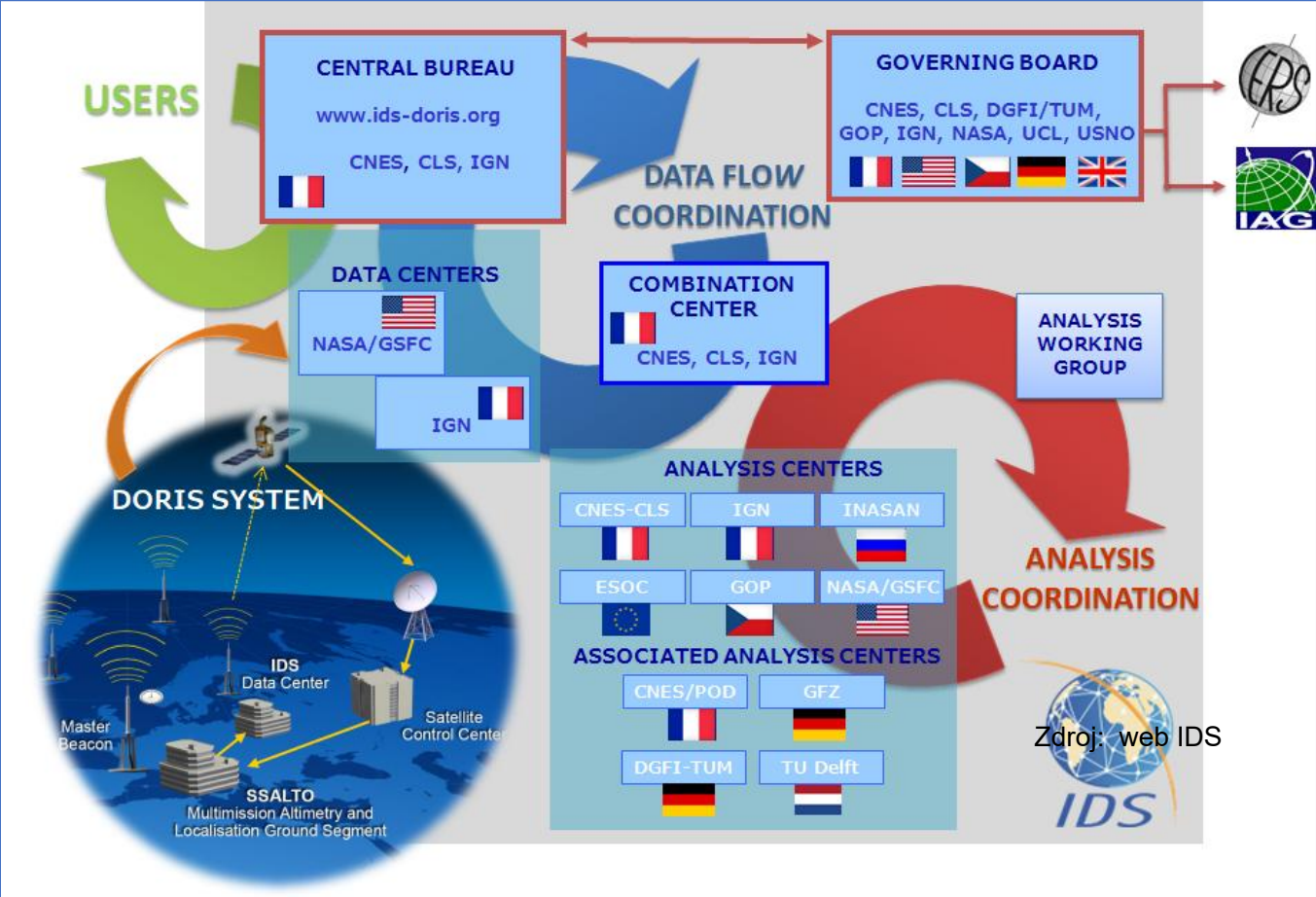



DORIS analysis worldwide

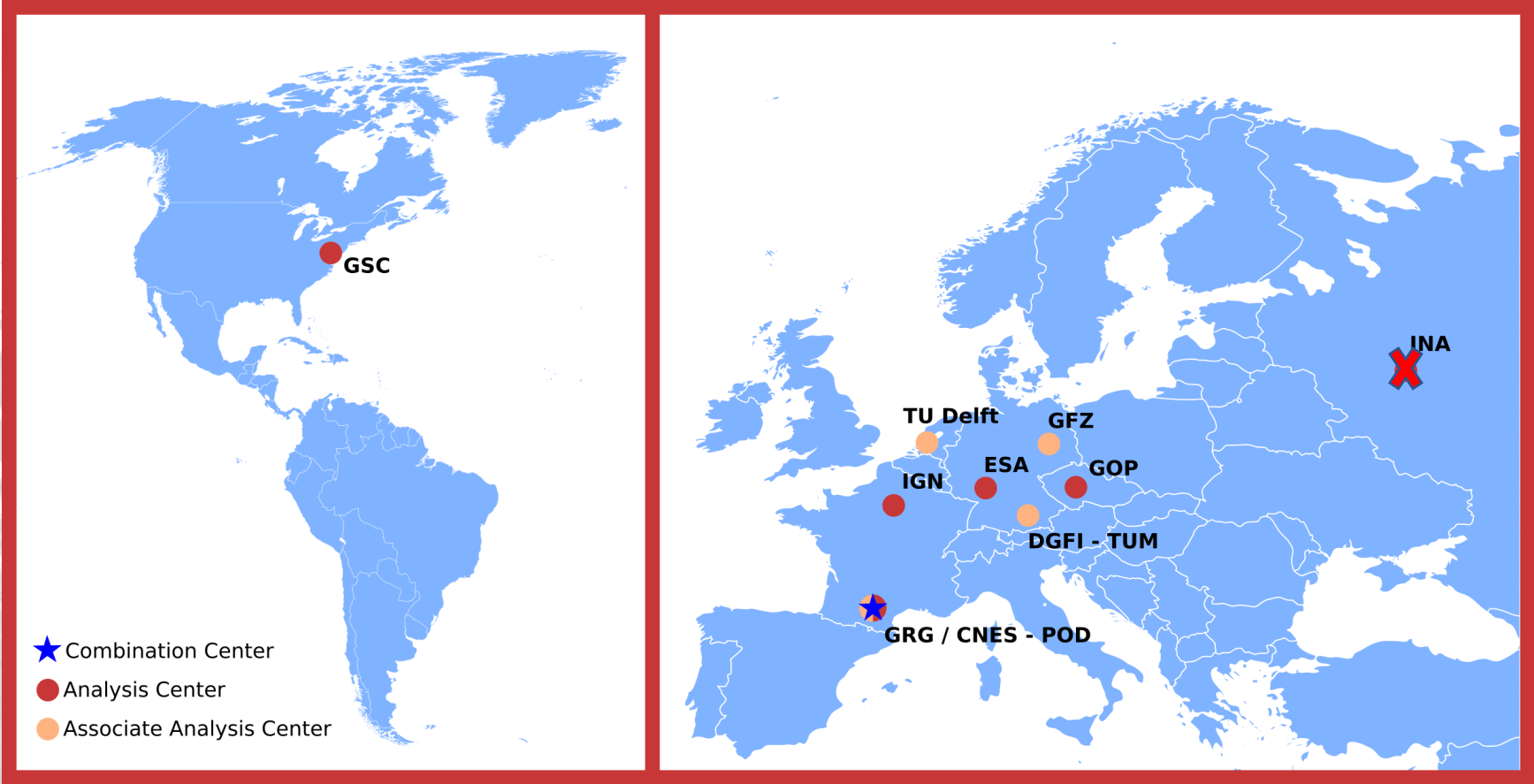



IDS analysis centers

AC	Software	Solution Type	EOPs	ITRF2014	ITRF2020	ITRF20XX
ESA	EPNS	NEQ	offset+rate+LOD	X	X	X
GOP	BERNESE	COV	offset+rate+LOD	X	X	X
GRG	GINN-DYNAMO	COV	offset	X	X	X
GSC	GEODYN	NEQ	offset	X	X	X
IGN	GIPSY-OASIS GIPSY-X	NEQ	offset	X		X
GFZ*	EPOS-OC	NEQ	offset+LOD			X
IDS	CATREF	COV	Offset+LOD			

*under evaluation

IDS contribution to the next ITRF realization may be based on 6 IDS AC solutions from 6 different software packages.



Scale and Origin wrt ITRF2020-u2023

Generation of DORIS receiver



Time period: 1993.0-2025.5

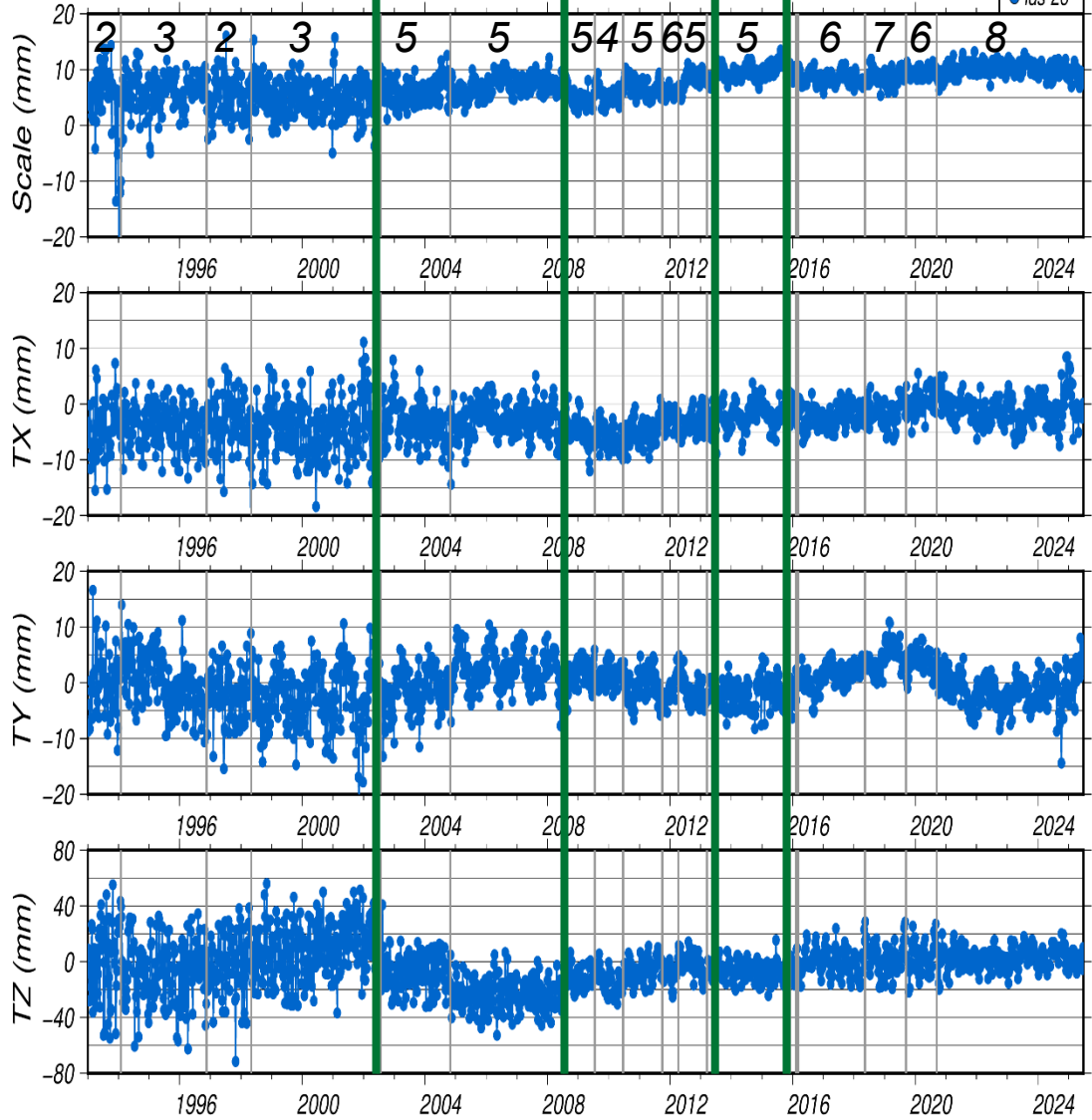

Nb of satellites

Scattering is reduced:

- When more satellites are available.
- With the evolution of DORIS receiver capabilities.

DORIS scale is quite stable since mid-2012 (lies in a range of ± 2.50 mm, trend of about 0.11 mm/yr).



Station Position WRMS wrt cumulative solution

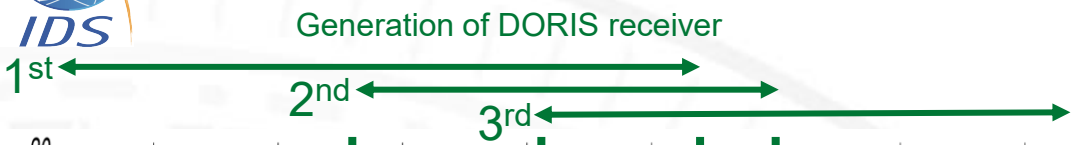

Time period: 1993.0-2025.5

Nb of satellites

- Results improved:**
- When more satellites are available.
 - With missions with different inclinations.
 - With the evolution of DORIS receiver capabilities.

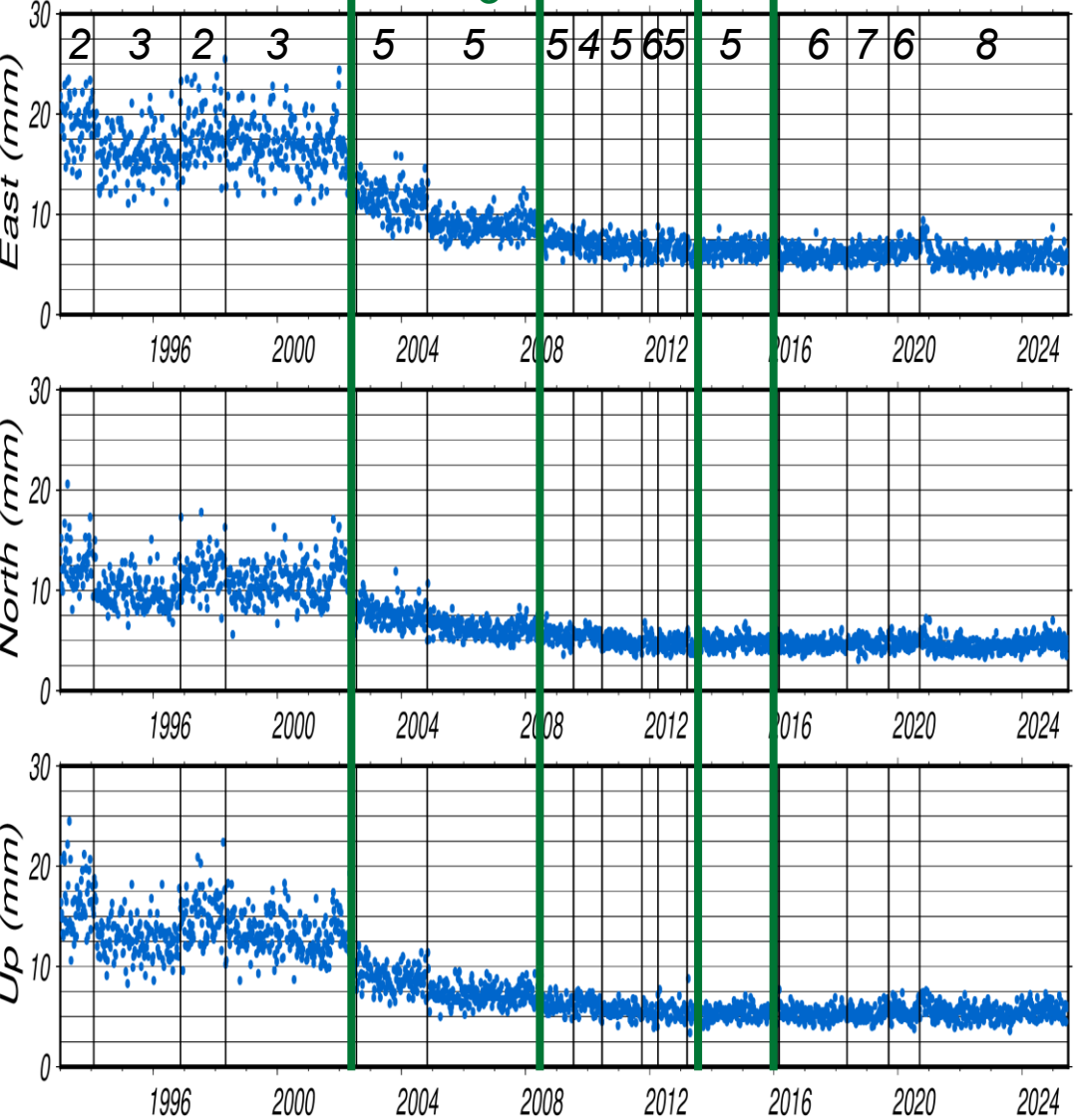

Time Period	East [mm]	North [mm]	Up [mm]
1993.0-2002.5	17.1 ± 2.6	10.9 ± 2.1	13.7 ± 2.4
2002.5-2008.5	9.9 ± 1.8	6.8 ± 1.2	7.9 ± 1.3
2008.5-2015.9	6.7 ± 0.8	5.0 ± 0.7	5.7 ± 0.8
2015.9-2021.0	6.2 ± 0.8	4.8 ± 0.6	5.5 ± 0.7
2021.0-2025.5	5.7 ± 0.7	4.6 ± 0.6	5.5 ± 0.7



ERP Residuals wrt IERS C04

Time period: 1993.0-2025.5

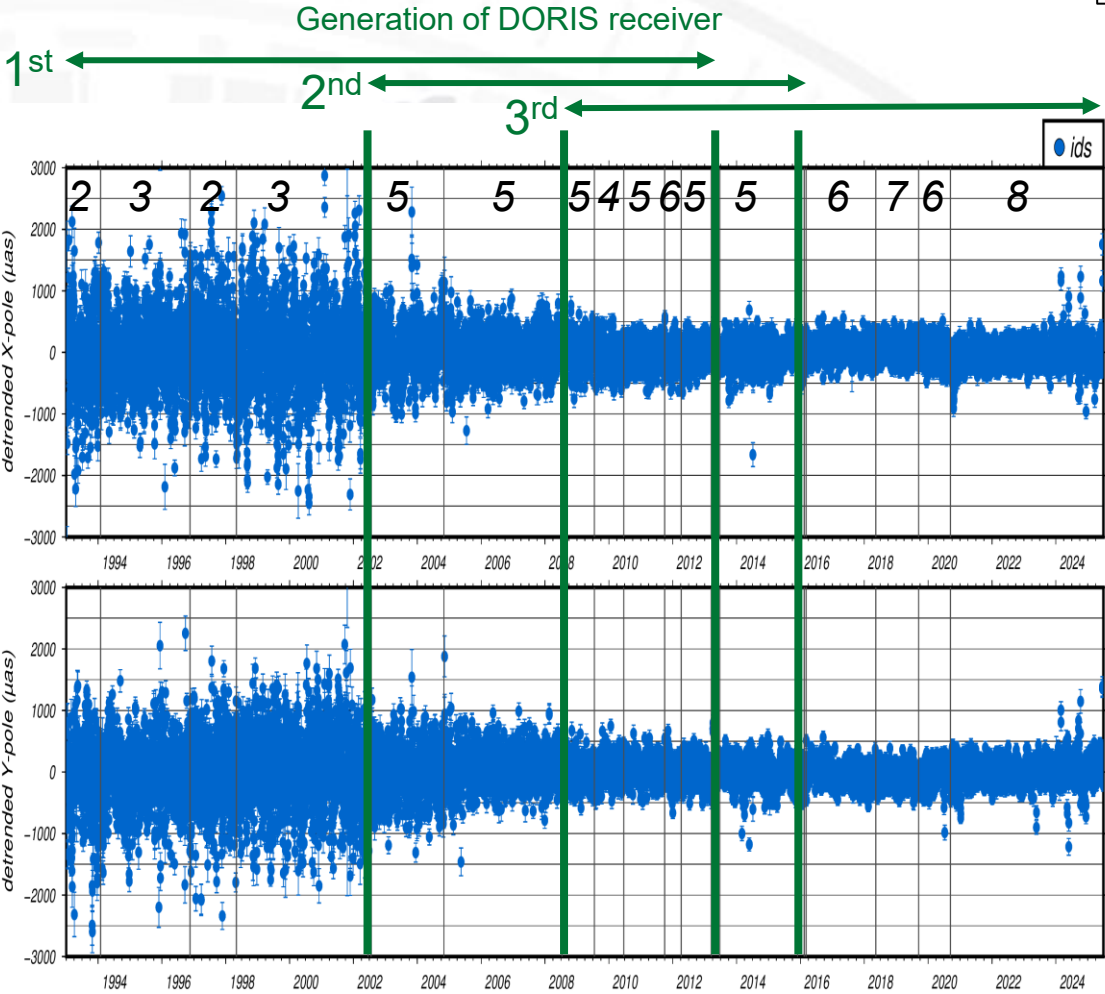

Nb of satellites

Time Period	X-pole [μas]	Y-pole [μas]
1993.0-2002.5	-0.2 ± 649.6	-4.9 ± 573.9
2002.5-2008.5	2.1 ± 327.5	1.4 ± 314.0
2008.5-2015.9	-1.3 ± 203.8	0.0 ± 193.5
2015.9-2021.0	-1.6 ± 169.1	-0.6 ± 162.3
2021.0-2025.5	2.4 ± 189.2	-0.2 ± 183.3

Results improved:

- When more satellites are available.
- With the evolution of DORIS receiver capabilities.

Impact of increased solar activity

- ❑ **Develop a strategy to mitigate the impact of increased solar activity on POD and the multi-satellite solution (preliminary study)**

The atmospheric density varies significantly during periods of high solar activity, which strongly affects low-altitude satellites due to the difficulty of accurately modeling the atmosphere.

All DORIS satellites at lower altitudes are impacted (excluding Sentinel-6A and Jasons satellites which are higher).

First, we tried to adjust more drag coefficients (from 1 coefficient every 4 hours to 1 coefficient every hour), and we also tested other models of thermosphere (as NRLMSIS 2.0), but the results were not satisfactory.

We know that GPS orbits are less impacted by solar activity due to the increase in solar flux. Indeed, in GPS processing, we can compute a reduced-dynamic orbit because the number of observations is much greater than in the case of DORIS processing over a pass duration. Therefore, we attempted to adjust a stochastic force to mitigate the impact on DORIS-only orbits.

Then we created a new series, grg66, and processed DORIS data from August 2021 to September 2025, by adjusting one drag coefficient per hour **and by adjusting a stochastic force every two hours.**



Impact of increased solar activity on POD

Comparison to POE-G orbit

Daily RMS radial orbit differences (in cm)

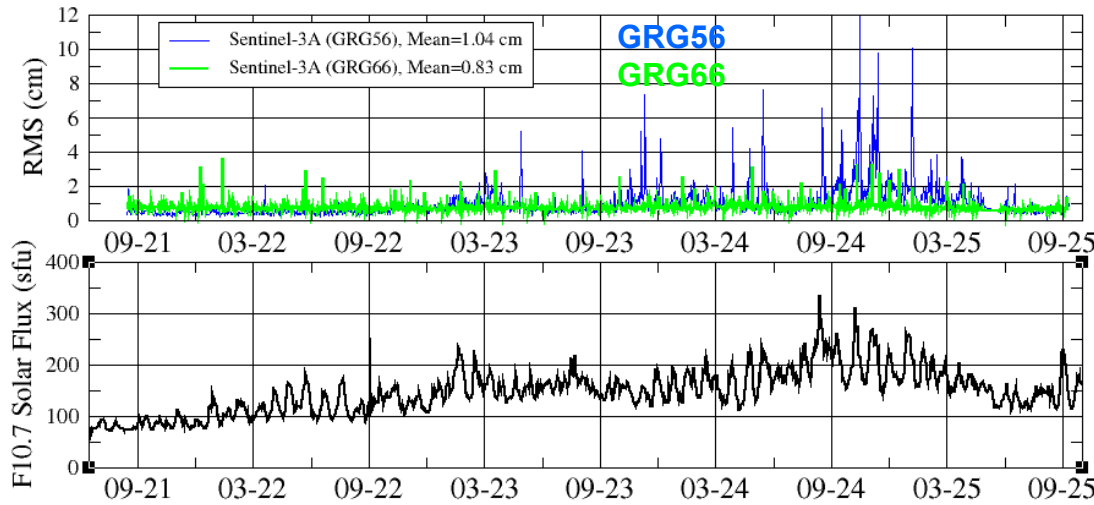

(from Aug. 2021 to Sept. 2025)

Orbit Comparison to POE-G (Mean of daily RMS (cm))			
	Radial	Along-track	Cross-track
GRG56	1.04	2.90	1.80
GRG66	0.83	2.30	1.74

- For Sentinel-3A, compared to the operational series grg56 (in blue), the agreement between the GRG orbit and the POE-G orbit improves when adjusting a stochastic force (grg66 in green) as solar flux increases. For the radial component, several peaks disappear. The mean daily RMS values are reduced for all components.



South Atlantic Anomaly – the origin of the phenomenon

- Van Allen Belts – trapped high energy protons and electrons
- Symmetric with respect to the magnetic field lines of force
- Earth magnetic field is asymmetric w.r.t. Earth surface and the weakest in the South Atlantic region
- Inner Van Allen Belts are closer to the Earth surface in the South Atlantic region

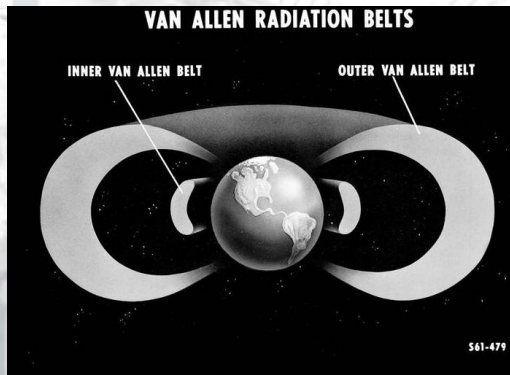

Source: spacecenter.org

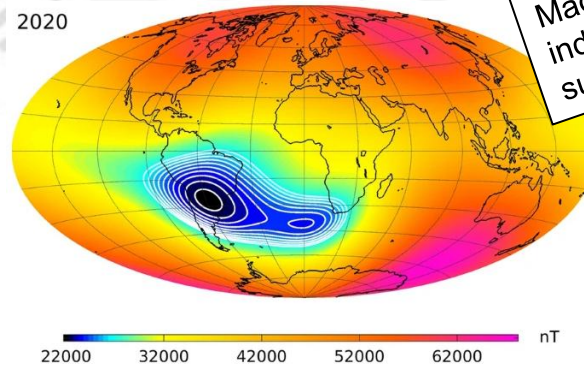

Source: Adler (2021)

Observation residuals for stations, Hy-2C and Hy-2D

- Strong SAA effect for Hy-2C

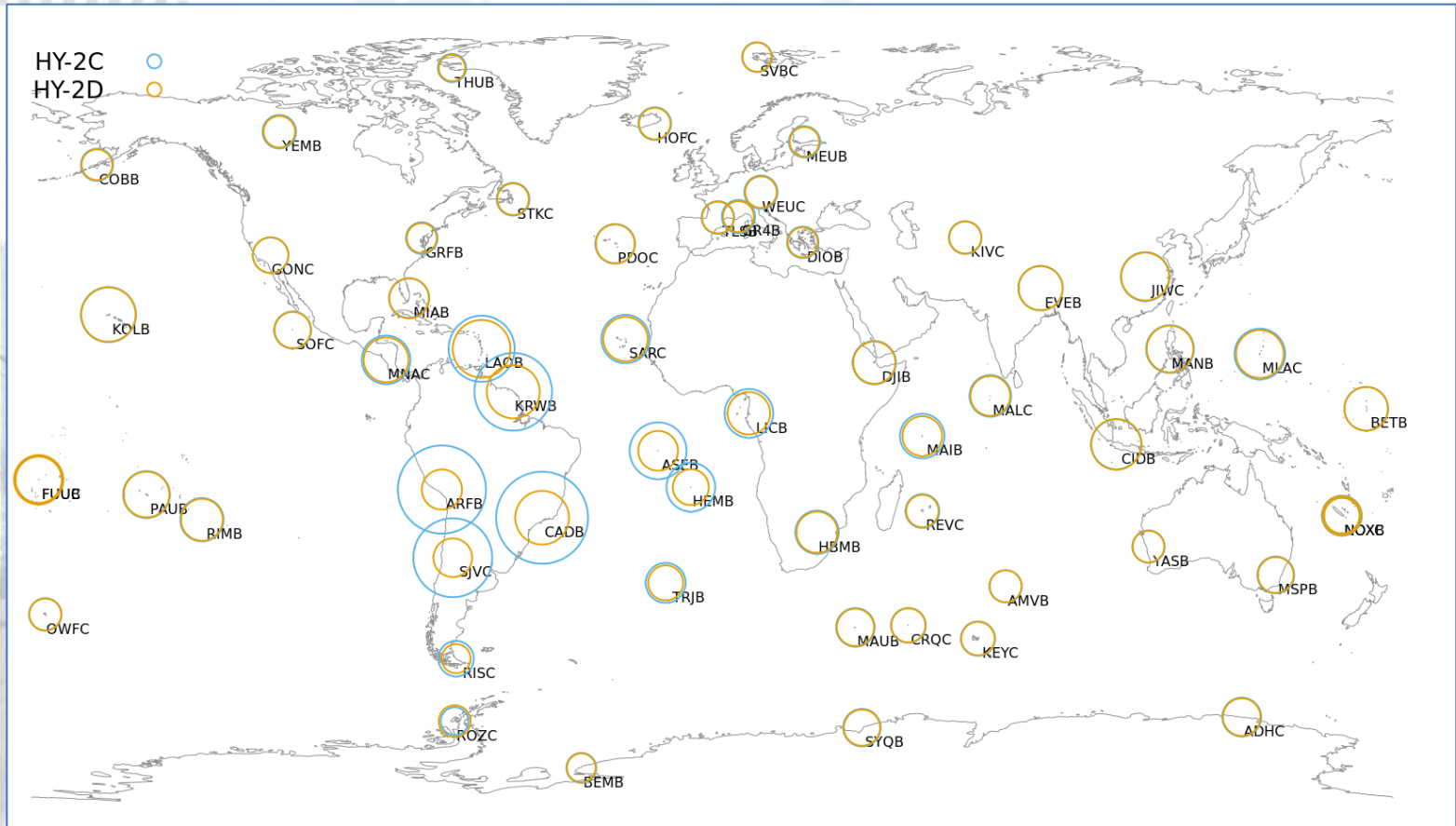

SAA Sentinel maps

- **USO frequency relative offset in 10^{-12}**
- **Different sign for both Sentinels**
- **Different shape of the SAA area for both Sentinels**

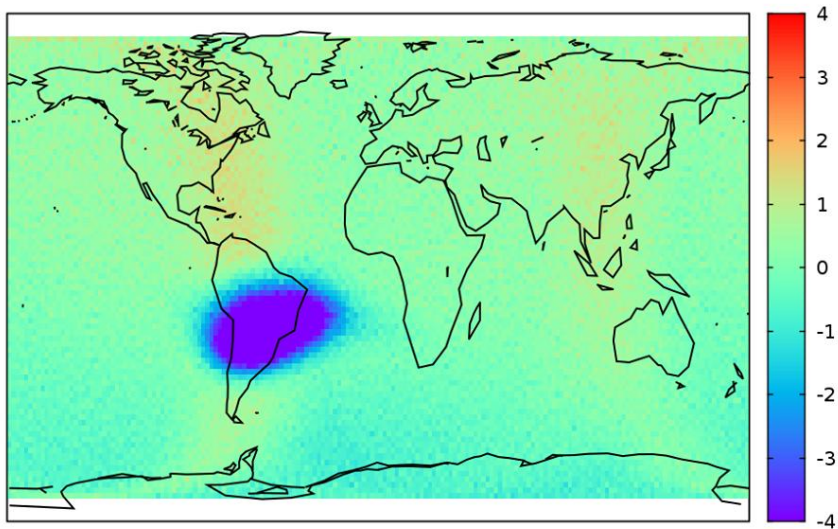

Sentinel-3A

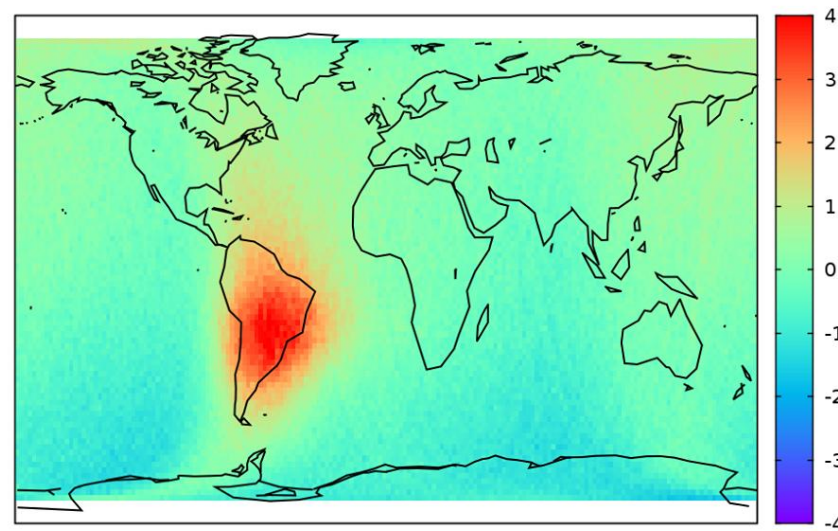

Sentinel-3B

Impact of the integration of GPS clocks on the orbit

□ RMS of fit (in mm/s) per DORIS stations from GRG POD processing
Average from January 2021 through December 2024

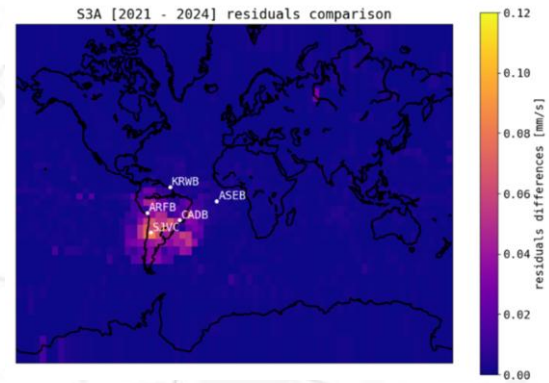
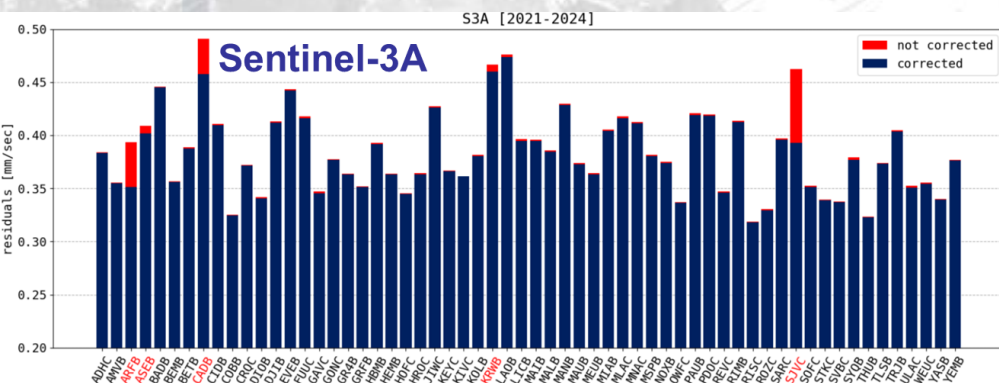
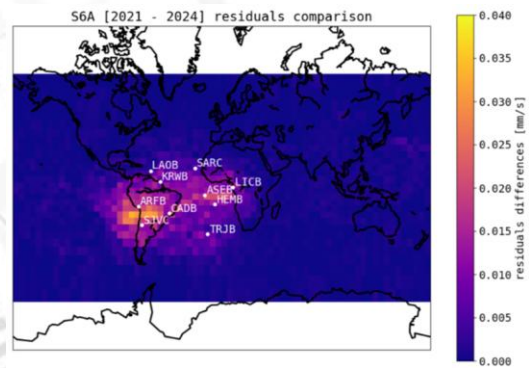
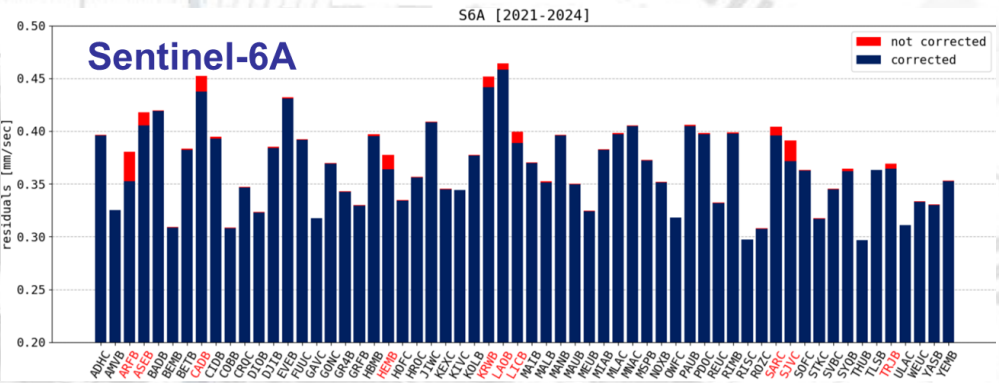

■ For Sentinel-6A and Sentinel-3A

The correction significantly reduces the RMS residuals of SAA stations.

Impact of the GNSS clocks integration on the station positioning

❑ Single satellite Solution compared to DPOD2020 (computed by CATREF)

Positioning Residual STD - Time series of DORIS coordinates w_o and w_c correcting the SAA stations.
 After removing the long-term trend, we compare the residual noise levels (STD) in NEU components.

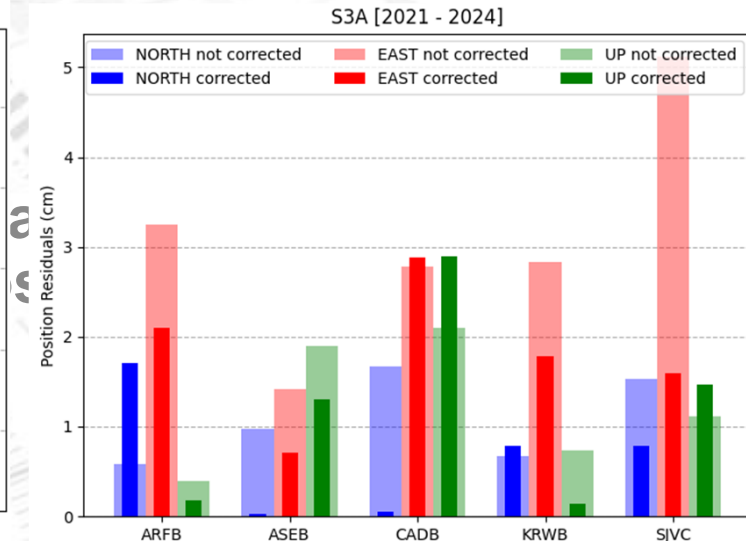
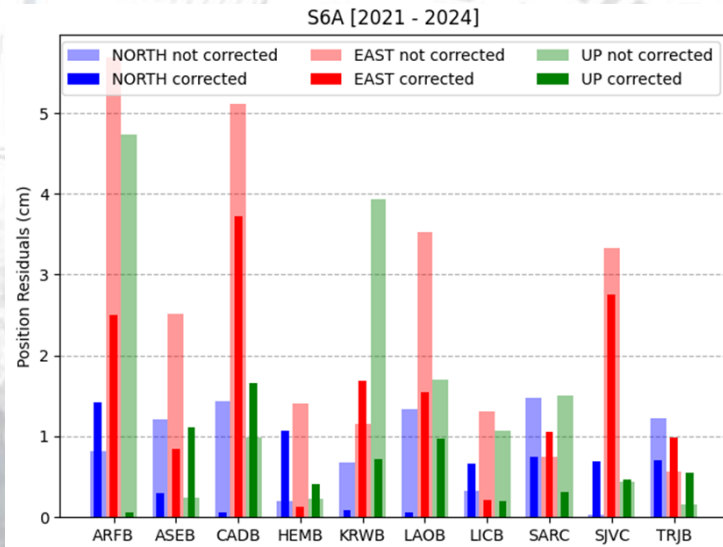

- *The integration of Sentinel GPS clocks significantly reduces the positioning residual standard deviation (STD) for stations located in the SAA area.*



SWOT SATELLITE

Relevant elements on SWOT architecture

- S/C velocity along +/- Body X directions.
- -Y is always toward the Sun.
- Spacecraft performs yaw flips (apx. every 78 days) to keep radiator (i.e., +Y) in shade.
- One solar panel on each side of spacecraft bus along body-fixed +/- X directions.
- Radiators are located on +Y side of the spacecraft.
- Solar panels are always oriented towards -Y, taking three β -dependent positions.
- For CNES POD, the Solar Radiation Pressure (SRP) model is a cube with two solar panels

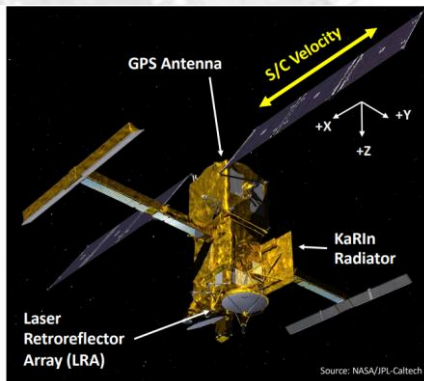

β	Solar array angle
$[0^\circ - 6^\circ]$	0°
$[6^\circ - 25^\circ]$	12°
$> 25^\circ$	30°

SRP With AND W/O SHADOW

- ❑ Acceleration computation using GINS software
- ❑ Three models, one for each solar array position
- ❑ Satellite modelled with a main body, solar arrays, Karin and radiators
- ❑ Main shading effects on:
 - ❑ The tangential acceleration, for beta $< \sim 40^\circ$
 - ❑ The normal acceleration, for beta $> \sim 60$, with a bias

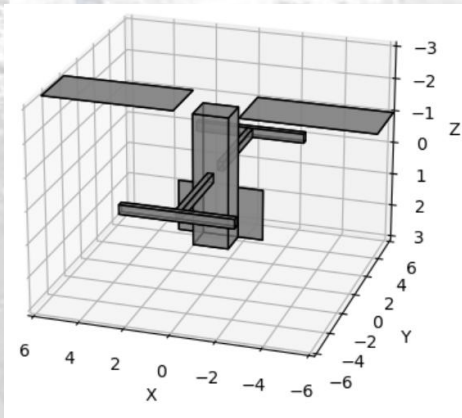

3D model for beta $< 6^\circ$

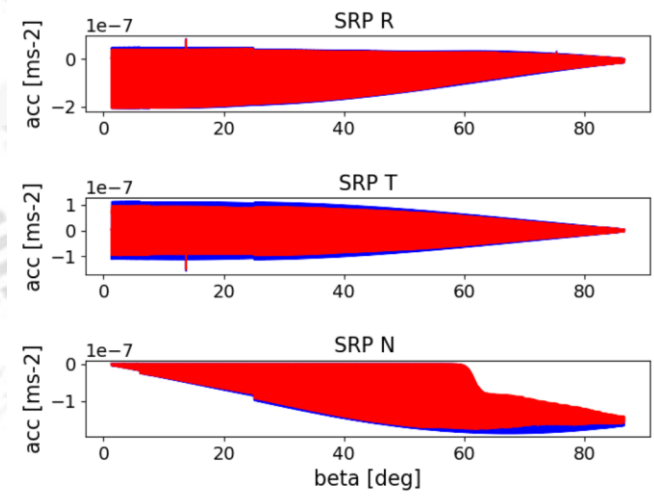

SRP in RTN, blue without self shadow, red, with self shadow



Orbit difference

Preliminary work using ZOOM software and the acceleration from GINS instead of the ZOOM nominal SRP model.

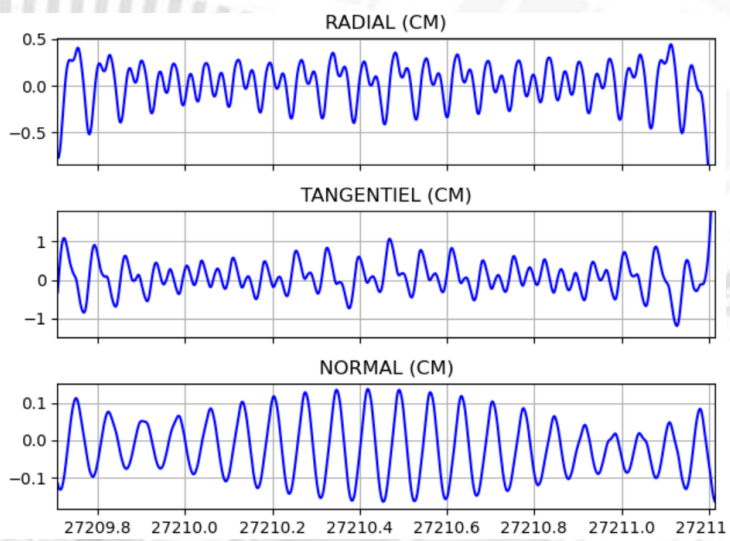

Beta Angle close to 0 deg
1cm error on T, with signatures at 1/rev, 2/rev
0,1cm error on N, unbiased

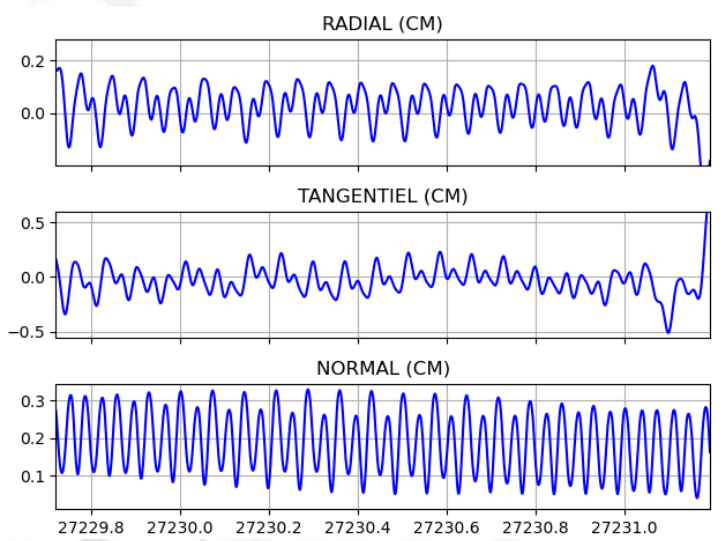

Beta angle close to 60 deg
0,2cm error on T, with signatures at 1/rev, 2/rev
0,1cm error on N, 0,2cm bias



WG Iono Applications

- New IDS WG - **NRT Ionospheric Applications**

Chair: Ningbo Wang (AIR/CAS, China)

Vice-chair: Philippe Yaya (CLS, France)

- ▶ IDS Governing Board approved the new Working Group on 6 November 2024
- ▶ Working Group webpage available at the IDS website*
- ▶ Working Group mailing-list created for communication ids.wgiono@ids-doris.org

Objectives

- Propose standardized NRT DORIS data processing technique for ionospheric analysis
- Develop algorithms to enable NRT DORIS data for ionospheric application
- Advance the use of NRT DORIS data in combination with other geodetic observation data for near-real-time or even real-time ionospheric modeling and monitoring
- Identify possible users and additional applications of NRT DORIS data
- Evaluate the possibility to establish a new NRT DORIS based ionospheric production chain

*Detailed information: <https://ids-doris.org/ids/organization/working-groups.html>



WG Iono Applications

► DORIS-derived differential Slant TEC (dSTEC) dSTEC*

NRT DORIS dSTEC product

Filename: **CAS00PS***NRT*_**\$YYYY****\$DOY0000**_DRS_**\$SSS**_ION.DSTEC.gz

- \$YYYY: Year (e.g., 2023)
- \$DOY: Day of Year
- \$SSS: Satellite Identifier (e.g., JA3 for Jason-3)

Example: CAS00PSNRT_20231820000_DRS_JA3_ION.DSTEC.gz

Product archive: <https://data.bdsmart.cn/pub/product/iono/nrtdoris/dstec/>

FINAL DORIS dSTEC product

Filename: **CAS00PS***FIN*_**\$YYYY****\$DOY0000**_DRS_**\$SSS**_ION.DSTEC.gz

Product archive: <https://data.bdsmart.cn/pub/product/iono/doris/dstec/>

*Detailed information: <https://ids-doris.org/data-products/tables-of-data-products/product-doris-dstec.html>



Come and join the IDS community

- Read IDS **publications** available at <https://ids-doris.org>

Newsletters

Regular information on the DORIS system and the life of IDS.

Annual activity reports

Progress reports about IDS, DORIS system, user service, analysis activities.

- Meet IDS members and DORIS experts at **meetings**

IDS Analysis Working Group (twice a year)

IDS Workshop (every two years)

and also at AGU, EGU, IAG assemblies, GGOS events ...

- Attend **courses** organized by IDS

DORIS Days

- Follow us on **LinkedIn #idsdoris**

- Subscribe to IDS information **mailing list dorismail**

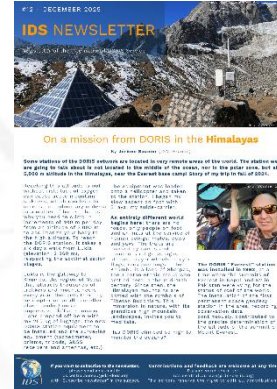

The **2026 IDS Workshop** will take place in Wiesbaden, Germany, from 23 to 25 June 2026, in conjunction with OSTST 2026.



IDS website: <https://ids-doris.org>
 Contact: ids.central.bureau@ids-doris.org
 LinkedIn: <https://www.linkedin.com/company/ids-doris>