



CENTRE NATIONAL D'ÉTUDES SPATIALES

HY-2C

**INPUT DATA FOR HY2C PRECISE ORBIT  
DETERMINATION**

**Issue 2.0**

## ABBREVIATIONS

Acronym	Definition
BDR	Boîtier DORIS redondé
LRA	Laser Reflector Array
SA	Solar Array
SC	SpaceCraft
POD	Precise Orbit Determination

## INDEX

<b>1. PURPOSE OF THE DOCUMENT .....</b>	<b>4</b>
<b>2. APPLICABILITY .....</b>	<b>4</b>
<b>3. OVERALL MISSION DESCRIPTION .....</b>	<b>4</b>
<b>3.1 BEGINNING OF LIFE.....</b>	<b>4</b>
<b>3.2 PLANNED CHANGES OF THE ORBIT.....</b>	<b>4</b>
<b>3.3 MISSION ORBIT CHARACTERISTICS.....</b>	<b>4</b>
3.3.1 ORBIT 1.....	4
3.3.2 ORBIT 2.....	5
<b>3.4 ORBIT CONTROL MANOEUVERS .....</b>	<b>6</b>
<b>3.5 ATTITUDE MODE .....</b>	<b>6</b>
3.5.1 NOMINAL ATTITUDE .....	6
3.5.2 ATTITUDES CHANGES .....	6
<b>3.6 SATELLITE SAFEHOLD MODES.....</b>	<b>7</b>
<b>4. SATELLITE DESCRIPTION.....</b>	<b>8</b>
<b>4.1 SATELLITE VIEW AND REFERENCE FRAME .....</b>	<b>8</b>
<b>4.2 SATELLITE MOBILE PARTS .....</b>	<b>10</b>
4.2.1 SOLAR ARRAY .....	10
4.2.2 OTHER .....	10
<b>4.3 MASS PROPERTIES .....</b>	<b>10</b>
<b>4.4 SATELLITE SURFACES .....</b>	<b>11</b>
<b>4.5 DORIS ANTENNA REFERENCE POINTS.....</b>	<b>12</b>
<b>4.6 DORIS ANTENNA ENVIRONMENT.....</b>	<b>13</b>
<b>4.7 CABLE LOSSES.....</b>	<b>13</b>
<b>5. DORIS RECEIVER DESCRIPTION.....</b>	<b>13</b>
<b>5.1 DORIS RECEIVER PARAMETERS .....</b>	<b>13</b>
<b>5.2 ANTENNA GAINS.....</b>	<b>14</b>
<b>5.3 ANTENNA PHASE CENTER .....</b>	<b>14</b>
<b>5.4 ANTENNA PHASE LAWS .....</b>	<b>15</b>
<b>6. LASER REFLECTOR ARRAY DEFINITION.....</b>	<b>16</b>
<b>7. GPS INSTRUMENT DESCRIPTION .....</b>	<b>16</b>
<b>7.1 GPS ANTENNA .....</b>	<b>16</b>
7.1.1. GPS ANTENNA PHASE CENTER .....	16
7.1.2. GPS ANTENNA PHASE CALIBRATION .....	17
7.1.3. GPS ANTENNA AXES .....	17

## **1. PURPOSE OF THE DOCUMENT**

This document describes the information required to ensure optimal parameterisation of on-board and ground POD processing software in the HY2 context.

The first issue of this document is filled with available information (RD1, DORIS previous models)

Chapters 3, 4 and 6 shall be filled/agreed by the satellite provider.

Chapter 5 shall be filled/agreed by the provider of the DORIS receiver.

## **2. APPLICABILITY**

This document is applicable to the DORIS/HY2 project during the development, system test, and flight acceptance and operation phases.

## **3. OVERALL MISSION DESCRIPTION**

A complete description of the mission is necessary, in order to perform DORIS mission analysis.

### **3.1 BEGINNING OF LIFE**

At DORIS switch-on the satellite is:

- 3-axes stabilized
- Earth pointed

### **3.2 PLANNED CHANGES OF THE ORBIT**

For each Mission Orbit, the characteristics are detailed in the following paragraph.

### **3.3 MISSION ORBIT CHARACTERISTICS**

Two different orbits will be used during the mission (RD1).

#### **3.3.1 ORBIT 1**

The ORBIT 1 is defined as:

- Repeat cycle Days: 10
- Half axis: 7328.583 km, average height: 957.583 km
- Inclination: 66°
- Eccentricity rat: 0.000012
- Intersection period: 104.1048 min
- Cycle number: 137 , 13 + 7/10 ring per day

- Intercept in equator: 292.5185 km

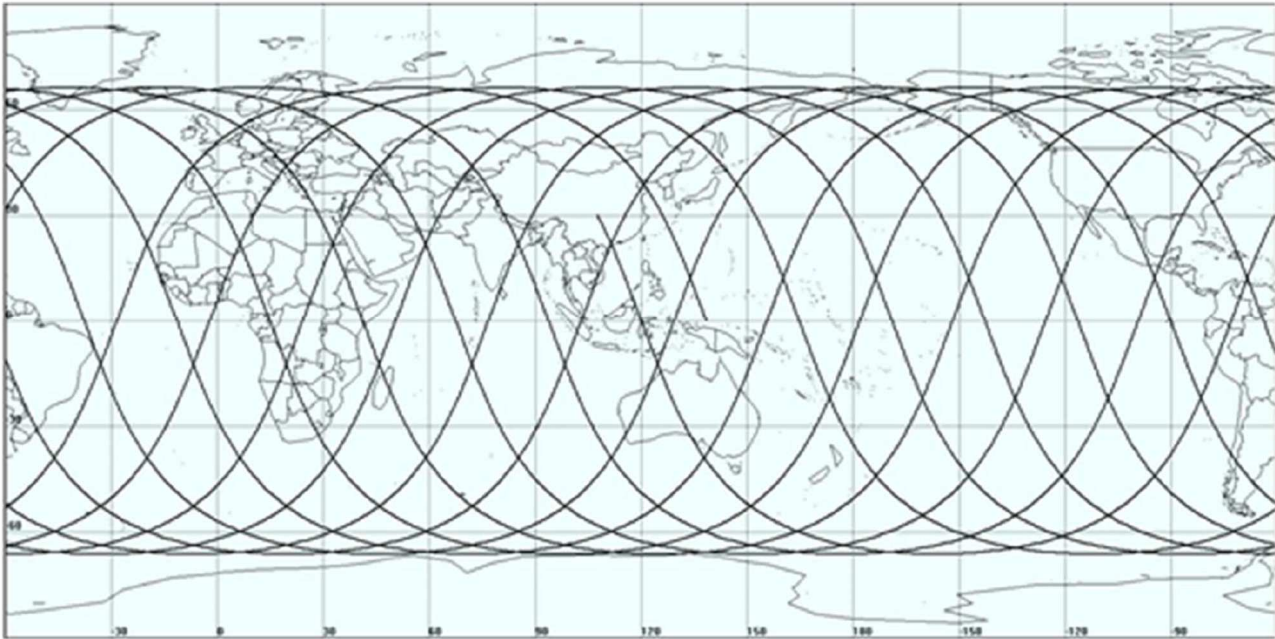

**One day track**

### 3.3.2 ORBIT 2

The ORBIT 2 is defined as:

- Repeat cycle days: 400
- Half axis: 7329.490 km, average height: 958.490 km
- Inclination: 66°
- Eccentricity rat: 0.000012
- Intersection cycle: 104.1241 min
- Total number of one cycle: 5479 , 13 + 279/400 ring every day
- Intercept in equator 7.3143 km

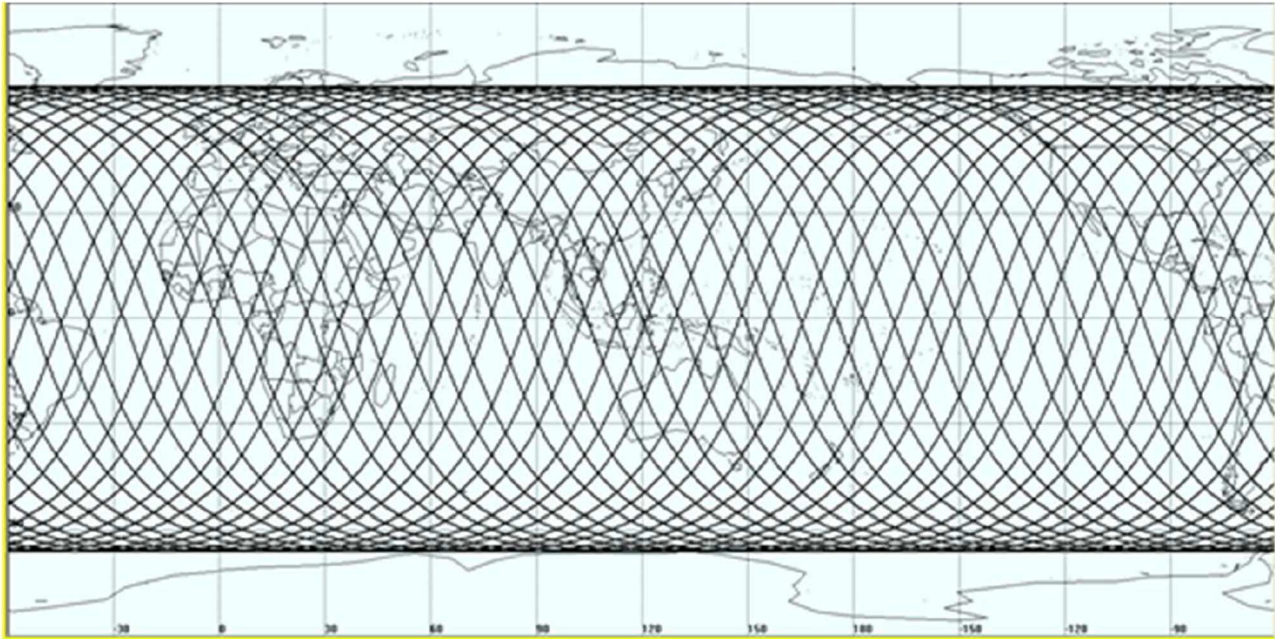

**3 days track**

### **3.4 ORBIT CONTROL MANOEUVERS**

Directions: along flight axis

Typical duration: 10 ~ 30s

Typical acceleration of thrusts: 1N (2)

Frequency of the manoeuvres: about 30 days

### **3.5 ATTITUDE MODE**

#### **3.5.1 NOMINAL ATTITUDE**

The attitude is controlled by inertial wheels.

The nominal attitude of the satellite is: Earth-pointed

With the following accuracy:

- Point precision: Pitching, roll and yawing  $<0.1^\circ$
- Measure precision: pitching, roll and yawing  $< 0.03^\circ$
- Three axis pose stability  $<0.003^\circ/s$

#### **3.5.2 ATTITUDES CHANGES**

If altimeter calibration manoeuvres are planned they shall be describe here after: TBD

If any Yaw Steering model is used it shall be described:

- the -x-axis is pointing towards the sun
- the +z-axis is pointing towards the earth surface.

### **3.6 SATELLITE SAFEHOLD MODES**

In order to avoid DORIS receiver reference clock ageing recovery leading in POD degradation it is recommended to maintain DORIS ON during satellite safe hold modes.

On board HY2 DORIS is TBD during safe hold mode.

#### 4. SATELLITE DESCRIPTION

The following parameters shall be representative of the satellite characteristics; in order to reach the performances needs by the mission.

The values will need to be updated during the satellite lifetime, if any major change occurs.

##### 4.1 SATELLITE VIEW AND REFERENCE FRAME

A view of the satellite in flight configuration, indicating the satellite reference frame (X, Y and Z directions) is shown here after. The direction of the nadir is consistent with Z+ axis.

the -x-axis is pointing towards the sun, the +z-axis is pointing towards the earth surface if the solar incident angle is less than 3°.

The direction of 3 axis is the same as HY2A.

The DORIS antenna shall be signalled on the graph, and also other RF transmitting equipment.

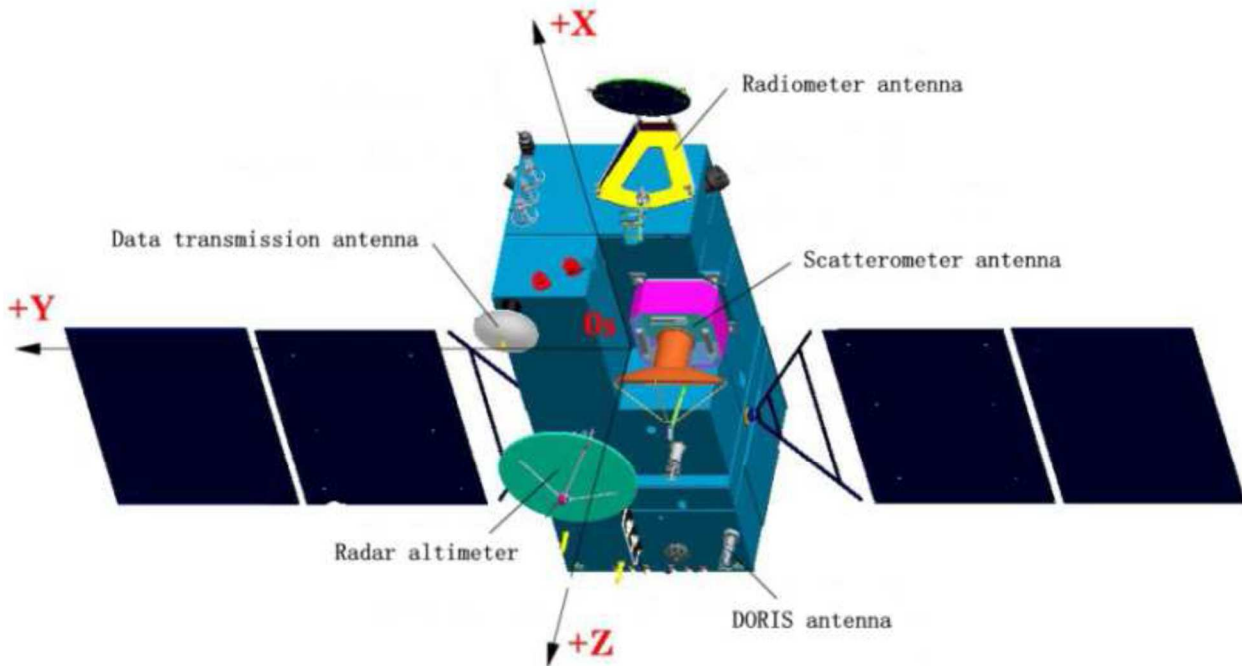

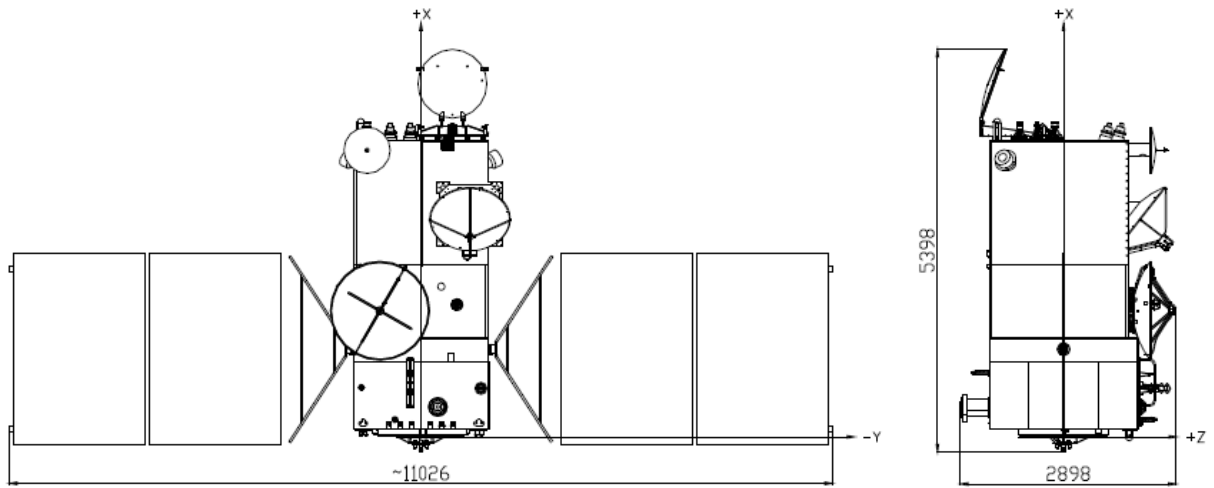

The dimensions of each SA panel defined in following figure:

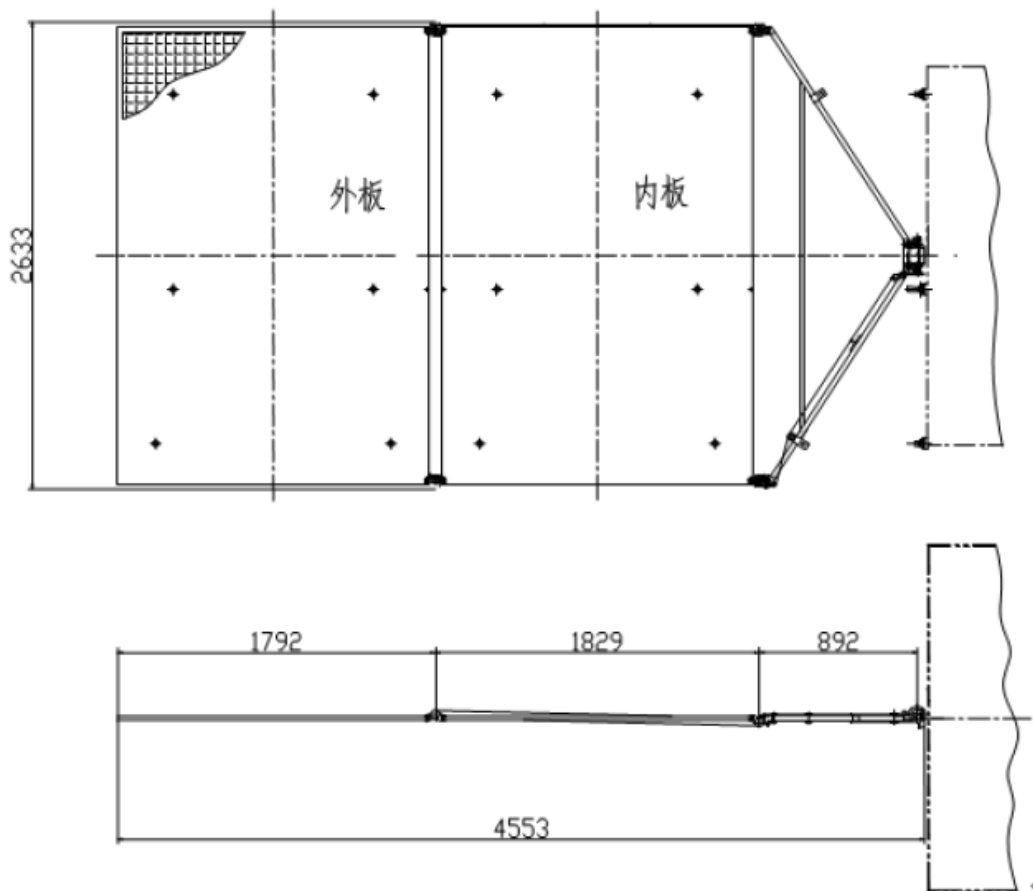

## 4.2 SATELLITE MOBILE PARTS

### 4.2.1 SOLAR ARRAY

Dimensions of SA are given in the figure ahead.

The impact of the motion of SA on the centre of mass is including in the paragraph mass properties here after.

### 4.2.2 OTHER

Mass, size and motion of other moving parts on board HY2 (if any) shall be précised.

## 4.3 MASS PROPERTIES

The values of:

- Beginning of Life Satellite mass (before orbit acquisition manoeuvre),
- Nominal Satellite total mass (beginning of mission, including moving parts if any),
- End of Life Satellite Mass

Shall be given with accuracy better than 1.0, kg.

The Centre of Mass coordinates shall be given in the Satellite Reference Frame with accuracy better than 1 mm.

The Centre of Mass coordinates uncertainties and their evolution during the satellite lifetime shall be précised in a final issue.

	<b>Satellite mass (kg)</b>	<b>X_cdg (mm)</b>	<b>Y_cdg (mm)</b>	<b>Z_cdg (mm)</b>
<b>Beginning of life</b>	1677.0	1332.0	-8.6	3.4
<b>Nominal operational mission</b>	1631.0	1357.7	-8.8	3.5
<b>End of life</b>	1591.0	1375.5	-9.0	3.6

The values shall be updated regularly in operation if relevant.

#### 4.4 SATELLITE SURFACES

The following values are used to build the solar pressure model, and shall be established as global values for each surface, taking into account the different properties of the different materials, and their respective contributions to the global coefficient.

The satellite surface properties (+X, -X, +Y, -Y, +Z, -Z and both face of the solar panel: front with the solar cells and rear size) for the solar spectrum and the infrared spectrum, shall be given:

- External Geometry satellite
- Thermo optical surface properties (Seculars Absorbed Diffuse in Visible and Infrared)
- Power (W) dissipated during typical operation by each radiating surface.

With this data the CNES build the SC box and wing simplified model which is a standard input for orbit determination.

SC box and wing simplified model		X+	X-	Y+	Y-	Z+			Z-	SA+ (Toward sun)	SA-
						OSR	SR-107 ZK	Carbon fibre			
Projected area (m <sup>2</sup> )		0.3329	0.375	2.614	2.326	1.891	2.325	0.665	1.717	18.1186	18.1186
Power dissipated typical operation (W)		56.5	63.7	444.0	395.1	471.5	373.2	86.8	247.4	12819.9	10721.1
Typical mean temperature in operation (°C)		-25	-25	-25	-25	0	-35	-45	-35	70	55
Visible	Specular	0.87	0.87	0.87	0.87	0.87	/	/	0.87	0.1	/
	Diffuse	/	/	/	/	/	0.14	0.15	/	/	0.1
	Absorbed	0.13	0.13	0.13	0.13	0.13	0.86	0.85	0.13	0.9	0.9
Infrared	Specular	0.22	0.22	0.22	0.22	0.22	/	/	0.22	0.08	/
	Diffuse	/	/	/	/	/	0.12	0.15	/	/	0.1
	Absorbed	0.78	0.78	0.78	0.78	0.78	0.88	0.85	0.78	0.92	0.9

#### Projected areas of radiator

SC box and wing simplified model		X+	X-	Y+	Y-	Z+	Z-
Projected area (m <sup>2</sup> )		3.621	3.920	5.173	5.461	3.060	6.224
Power dissipated typical operation (W)		127.3	1086.9	312.0	329.4	531.7	338.9
Typical mean temperature in operation (°C)		-100	17	-75	-75	-15	-80
Visible	Specular	0.65	0.65	0.65	0.65	0.65	0.65
	Diffuse	/	/	/	/	/	/
	Absorbed	0.35	0.35	0.35	0.35	0.35	0.35
Infrared	Specular	/	/	/	/	/	/
	Diffuse	0.31	0.31	0.31	0.31	0.31	0.31
	Absorbed	0.69	0.69	0.69	0.69	0.69	0.69

### Projected areas of multilayer

Lessons learnt from previous DORIS missions show that photos of each face of the satellite in final configuration are using full. These photos shall be annexed to the present document. In order to have a complete set of photos defining the satellite sequences of photos are necessary.

- One before SA mounting in order to show the radiators without any mask;
- One in final configuration before launch.
- One of the SA in deployed configuration (for example during SA deployment test). The both faces shall be shown.

Thermo optical characteristics of the different materials (Specular, absorbed, scattered) on visible and infrared shall be displayed related to the pictures. Required accuracy: better than 10%.

#### **4.5 DORIS ANTENNA REFERENCE POINTS**

The DORIS Antenna Reference Point is defined by the intersection of the antenna Z axis (revolution axes) and the mounting plane. The DORIS Reference point coordinates shall be given in the satellite reference frame with accuracy better than 1 mm

**X Coordinate of the DORIS reference point (mm): 710**

**Y Coordinate of the DORIS reference point (mm): -800.5**

**Z Coordinate of the DORIS reference point (mm): 1010.4**

DORIS antenna RF axis assumed orthogonal to the mounting plane is consistent with satellite Z axis with accuracy better than 1°.

**NB:** DORIS antenna RF axis shall be nominally pointed towards geocentric.

#### **4.6 DORIS ANTENNA ENVIRONMENT**

Masks shall be nominally avoided in the field of view of the antenna. However, if any limited mask remains it shall be carefully described: size, distance from the antenna, RF characteristics.

Masks, emitting/reflecting surfaces will lead to an accommodation feasibility study.

#### **4.7 CABLE LOSSES**

Losses due to onboard cables for each channel from the antenna bracket to the BDR bracket, including intermediate connector brackets if any.

	<b>400 MHz</b>	<b>2 GHz</b>
<b>Losses (dB)</b>	<b>TBD +/- 0.1 dB</b>	<b>TBD +/- 0.1 dB</b>
<b>Cable length ( m)</b>	<b>0.9 +/- 0.03 m</b>	<b>0.9 +/- 0.03 m</b>

These values are required to compute link budget and define level thresholds in data processing.

### **5. DORIS RECEIVER DESCRIPTION**

This data shall be gathered from acceptance data package.

#### **5.1 DORIS RECEIVER PARAMETERS**

The following parameters are necessary to process the DORIS data. Data shall be precised after delivery of the FM.

##### **temps transit bord IT3 400 MHZ UT1 to 7**

= 863 E-06 second +/- 1 microsecond

##### **Sensibility of the 400 MHz IT3 transit time WRT Doppler frequency**

=0,178 s +/-0.01s

##### **Temps transit bord IT3 2 GHZ UT1 to 7**

= 324 E-06 second +/- 1 microsecond

##### **Sensibility of the 2 GHz IT3 transit time WRT Doppler frequency**

=0, 18 s +/-0.01s

##### **400 MHZ Doppler delay UT1 to 7**

= 62.5 E-06 second +/- 1 microsecond

##### **2 GHZ Doppler delay UT1 to 7**

= 52.4 E-06 second +/- 1 microsecond

## 5.2 ANTENNA GAINS

Antenna gains tabulations:

$\theta_{\text{onboard}}$ value (angle between the onboard geocentric centripetal axis, and the propagation direction)	Values of gains (dBi) on the 400 MHz channel Accuracy = 1 dB	Values of gains (dBi) on the 2 GHz channel Accuracy = 1 dB
$\theta_{\text{onboard}} = 0^\circ$	5.5	4.0
$\theta_{\text{onboard}} = 10^\circ$	5.4	3.9
$\theta_{\text{onboard}} = 20^\circ$	5.0	3.3
$\theta_{\text{onboard}} = 30^\circ$	4.2	3.0
$\theta_{\text{onboard}} = 40^\circ$	3.5	2.1
$\theta_{\text{onboard}} = 50^\circ$	2.0	1.5
$\theta_{\text{onboard}} = 60^\circ$	0.5	1.0
$\theta_{\text{onboard}} = 70^\circ$	-1.3	-1.0

These values are required to compute the link budget and define level thresholds.

## 5.3 ANTENNA PHASE CENTER

The antenna phase centres for both 400 MHz and 2 GHz channels shall be defined in the antenna reference frame.

Frequency	X (mm)	Y (mm)	Z (mm)	Accuracy
401.25	0.	0.	152	+/- 5 mm
2036.25	0.	0.	313	+/- 5 mm

## 5.4 ANTENNA PHASE LAWS

Azimuth and Elevation Antenna phase laws shall be described according to the phase centre defined here above with accuracy better than 2.0 deg.

Variation of phase in elevation :

$\varepsilon$  ..... maximum deviation with regard to a law of constant phase  $\psi(\theta) = K \pm \varepsilon$

Frequency in MHz		401.25	2036.25
$-56^\circ \leq \theta \leq +56^\circ$		$\leq \pm 4^\circ$	$\leq \pm 2^\circ$
$\varepsilon$ value recorded for $\Phi$ values ( $-56^\circ \leq \theta \leq +56^\circ$ )	$0^\circ$	$\pm 1.5^\circ$	$\pm 1.5^\circ$
	$22.5^\circ$	$\pm 1.5^\circ$	$\pm 1.5^\circ$
	$45^\circ$	$\pm 1.5^\circ$	$\pm 1.5^\circ$
	$67.5^\circ$	$\pm 2.5^\circ$	$\pm 1.5^\circ$
	$90^\circ$	$\pm 2.5^\circ$	$\pm 1.5^\circ$
	$112.5^\circ$	$\pm 3^\circ$	$\pm 1.5^\circ$
	$135^\circ$	$\pm 2.5^\circ$	$\pm 2.5^\circ$
	$157.5^\circ$	$\pm 2.5^\circ$	$\pm 2.5^\circ$

Variation of phase in azimuth :

$\varepsilon$  ..... maximum deviation with regard to a law of linear phase  $\psi(\Phi) = K \Phi \pm \varepsilon$  ( $K = \text{constant}$ )

Frequency in MHz		401.25	2036.25
Specification $\varepsilon$ ( $-180^\circ \leq \Phi \leq +180^\circ$ )		$\leq \pm 4^\circ$	$\leq \pm 2^\circ$
$\varepsilon$ value recorded for following $\theta$ values	$10^\circ$	$\pm 1.0^\circ$	$\pm 1.5^\circ$
	$20^\circ$	$\pm 1.0^\circ$	$\pm 2^\circ$
	$30^\circ$	$\pm 1.5^\circ$	$\pm 2^\circ$
	$40^\circ$	$\pm 1.5^\circ$	$\pm 2^\circ$
	$56^\circ$	$\pm 2.0^\circ$	$\pm 2^\circ$
	$60^\circ$	$\pm 3.0^\circ$	$\pm 2^\circ$

## **6. LASER REFLECTOR ARRAY DEFINITION**

A view of the LRA shall be provided, indicating in the satellite reference frame (X, Y and Z directions) the position of the reference point (optical centre). Range corrections shall be also provided.

### **The 3-D location of the phase centre of the LRA relative to a satellite-based origin in the Satellite Navigation Body Coordinate:**

The phase centre of LRA is following only for normal incidence of laser beam.

**X Coordinate of the phase centre of LRA (m): +0.31281**

**Y Coordinate of the phase centre of LRA (m): -0.21568**

**Z Coordinate of the phase centre of LRA (m): +1.06046**

The range correction of LRA from spherical centre is 0.07448m.

### **The position and orientation of the LRA reference point (LRA mass-centre or marker on LRA assembly) relative to a satellite-based origin in the Satellite Navigation Body Coordinate:**

The spherical centre point (reference point) of LRA is following :

**X Coordinate of the spherical centre point (reference point) of LRA (m): +0.31281**

**Y Coordinate of the spherical centre point (reference point) of LRA (m): -0.21568**

**Z Coordinate of the spherical centre point (reference point) of LRA (m): +0.98598**

The LRA mass-centre point Coordinate is following :

**X Coordinate of the mass-centre point of LRA (m): +0.31281**

**Y Coordinate of the mass-centre point of LRA (m): -0.21568**

**Z Coordinate of the mass-centre point of LRA (m): +1.05716**

## **7. GPS INSTRUMENT DESCRIPTION**

*Some geometrical and electrical information are needed to use the GPS data in the POD.*

### **7.1 GPS ANTENNA**

*The data needed for the GPS antennae are for each antenna at each frequency channel L1 L2*

#### **7.1.1. GPS ANTENNA PHASE CENTER**

The GPS antenna phase centre point coordinates for each frequency channel is given in the Satellite Navigation Body Coordinate with accuracy better than 1 mm.

##### **GPS antenna 1**

**L1**

**X<sub>1</sub> Coordinate of the GPS antenna phase (m): +0.34729**

**Y<sub>1</sub> Coordinate of the GPS antenna phase (m): -0.17514**

**Z<sub>1</sub> Coordinate of the GPS antenna phase (m): -1.37468**

**L2**

**X<sub>1</sub> Coordinate of the GPS antenna phase (m): +0.34859**

**Y<sub>1</sub> Coordinate of the GPS antenna phase (m): -0.17304**

**Z<sub>1</sub> Coordinate of the GPS antenna phase (m): -1.39538**

##### **GPS antenna 2**

**L1**

**X<sub>2</sub> Coordinate of the GPS antenna phase (m): +0.43163**

**Y<sub>2</sub> Coordinate of the GPS antenna phase (m): +0.18232**

**Z<sub>2</sub> Coordinate of the GPS antenna phase (m): -1.37571**

**L2**

**X<sub>2</sub> Coordinate of the GPS antenna phase (m): +0.43213**

**Y<sub>2</sub> Coordinate of the GPS antenna phase (m): +0.18372**

**Z<sub>2</sub> Coordinate of the GPS antenna phase (m): -1.39631**

### **7.1.2. GPS ANTENNA PHASE CALIBRATION**

The phase diagram of the GPS Antennae at each frequency channel are needed

\*Numbers in the first row indicate angles in the azimuth plane ;

\*Numbers in the first column indicate angles in the vertical plane.

\*Other Numbers in the table indicate the phase calibration values corresponding to different angles.

The positive values mean phase advance, while the negative values mean phase lag.

### **7.1.3. GPS ANTENNA AXES**

The antenna axes orientation shall be given in the Satellite Navigation Body Coordinate with the accuracy better than 1 degree.

**X Coordinate of the GPS antenna axes orientation in the satellite reference frame (°): 90**

**Y Coordinate of the GPS antenna axes orientation in the satellite reference frame (°): 90**

**Z Coordinate of the GPS antenna axes orientation in the satellite reference frame (°): 180**