



Reference : CO-SP-D0-OP-2460-CN
 Revision : 15.0
 Date : 03/12/2004
 Page : 1/38

DORIS

MODELLING OF DORIS INSTRUMENTS

Written by:

C. JAYLES

Date and Signature

Authorized by:

J. NOUBEL

Date and signature

For approval:

A. AURIOL

S. COUTIN-FAYE

Date and signature

18/01/05
 po lauda

For application to	DS2	TP	DS4	DPP	DJ1	DS5	DH2	DJ2	DCY	D3S	SMM	
	X	X	X	X							X	
Models												

Configuration-managed document	YES	By : CCM DORIS then by : CCM SALP	As of : 11/10/90 As of : 03/12/04
Document status:			

CNES – 18, avenue E. Belin 31401 Toulouse cedex 9 – Tel : 0561273131

Ce document est la propriété du CNES. Les informations contenues dans celui-ci ne peuvent être communiquées, publiées ou reproduites sans l'accord préalable du CNES.

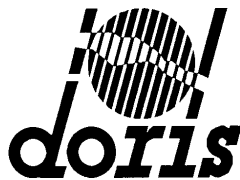
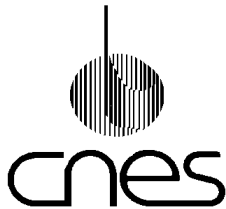

Reference : CO-SP-D0-OP-2460-CN
 Issue : 15.0
 Date : 03/12/04
 Page : 2/38

Title : Modelling of DORIS instruments

INDEXING SHEET

Confidentiality:	Limited to recipients on distribution list
Key words:	
Software used for creating the document:	Number of extra pages:
Author's summary:	

CHANGES

The changes with respect to the previous version are indicated by a vertical line on the left margin.

Revision	Date	Purpose
0.0	21/06/88	SCM/ESMN°255
1		- Updating of the τ_{m3} function (Doppler) - Incorporation of location beacon antenna - Calibration of the time frequency link between the laboratory and the Master beacon
2.0	11/10/90	- Introduction of the phase law for location type antenna (STAREC) - Correction of heights of the phase centre for DORIS location antennas which were incorrect - Changed pages i, iv, 2, 3, 13
3.0	22/06/96	Complete rewriting of the document to take into account all of the DORIS/SPOT 2, DORIS/SPOT 3, DORIS/SPOT 4 DORIS/TOPEX instruments This updating is a response to the GECCO n° 897 action. It is also a response to sheet no.4 RE/SU/TE/TP of 14/02/91 (design review for DORIS/POSEIDON ground system) Change of reference to comply with new PGD and new OT (previous ref.: DS2-NT-1-2460-CN)
4.0	10/10/96	Updating following the DM-108-CN (OM-236-CN) and incorporation of various comments and corrections following the investigation of this DM.
5.0	31/01/97	Updating following the DM-118-CN (OM-247-CN) and incorporation of various comments and corrections following the investigation of this DM
6.0	21/10/97	Updating following the DM-129-CN
6.1	09/10/98	Updating following the DM-146-CN (OM-333-CN) p.14
7.0	18/11/98	Updating following the DM-150-CN Rev. 1 and Rev. 2 (OM-342-CN) and the DM-170-CN (OM-353-CN)
8.0	10/01/00	Updating following the DM-203-CN
9.0	07/07/00	Updating following the DM-217-CN rév.1
9.1	10/10/01	Updating following the DM-CO-0-276-CN p.16 and 17
10.0	26/04/02	Updating following the DM-CO-0-292-CN Widening of the scope applicability
11.0	04/12/03	Updating following the DM-CO-0-336-CN . Change of OT code (previous reference: CO-SP-0-OP-2460-CN)
12.0	16/06/04	Updating following the DM-CO-D0-371-CN
13.0	16/09/04	Updating following the DM-CO-D0-373-CN
14.0	17/09/04	English translation : replace the french version
15.0	03/12/04	Updating following the DM-SALP-DM-M-253-CN (including DM DORIS DM-CO-D0-388-CN, DM-CO-D0-393-CN and DM-CO-D0-394-CN)

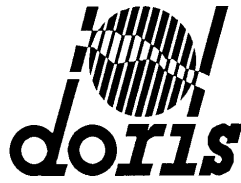

Reference : CO-SP-D0-OP-2460-CN
Issue : 15.0
Date : 03/12/04
Page : 3/38

Title : Modelling of DORIS instruments

APPLICABLE DOCUMENTS AND REFERENCE DOCUMENTS

Reference	Document title
DS2/DD/10/5	DR1. DOSSIER DE DÉFINITION DE L'INSTRUMENTATION (CHAPITRE : BILAN DES PERFORMANCES) ED. 2 EDITION PROVISoire [INSTRUMENT DEFINITION FILE (SECTION: PERFORMANCE EVALUATION) 2 ND DRAFT ISSUE]
CM-SP-06-2403-CN	DR2. SPÉCIFICATION D'INTERFACES ENTRE LE CENTRE DE CONTRÔLE ET LES INSTRUMENTS DORIS/SPOT [SPECIFICATION FOR INTERFACES BETWEEN THE CONTROL CENTRE AND THE DORIS/SPOT INSTRUMENTS]
DS2-IE-11-507-ESD	DR3. DORIS, DOSSIER DE RECETTE [DORIS ACCEPTANCE FILE]
DS2-SP-111-502-ESD	DR4. MIQ1 DORIS/SPOT 2 - LOIS DE CORRECTION DES MESURES DE DATATION T3 ESD. NE.339697 IND. 0 RÉV. 0 DU 09/09/88 [MIQ1 DORIS/SPOT 2 – CORRECTION LAWS FOR TIME-TAGGING T3 MEASUREMENTS ESD. NE.339697 IND. 0 REV. 0 DU 09/09/88]
DS2/NT-13-12	DR5. BILAN RF - ANTENNES BORD ET SOL DORIS/SPOT 2 . 1 DU 01/12/87 [RF BUDGET – DORIS/SPOT 2. 1 OF 01/12/87 ONBOARD AND GROUND ANTENNAS]
S-NT-20-3205-MT	DR6. BILAN DE MASSE SL SPOT 2 ED. 4 DU 25/01/88 [SPOT 2 SL MASS BUDGET, ISSUE 4 OF 25/01/88]
TP-SP-06-60-CN	DR7. SPÉCIFICATION D'INTERFACE ENTRE LE CENTRE DE CONTRÔLE ET L'INSTRUMENT DORIS/TOPEX [SPECIFICATION OF INTERFACE BETWEEN THE CONTROL CENTRE AND THE DORIS/TOPEX INSTRUMENT]
TP-IE-113-4830-SR	DR8. ANTENNE DE BORD DORIS – RAPPORT D'ESSAIS DE MODÈLE DE VOL MV2 RAPPORT N°2117 [DORIS ONBOARD ANTENNA – TEST REPORT FOR FLIGHT MODEL MV2, REPORT N°2117]
CM-NT-1-5096-CN	DR9. BILAN RF ANTENNES BORD ET SOL DORIS/SPOT 3 - DORIS/TOPEX [ONBOARD AND GROUND ANTENNAS – RF BUDGET FOR DORIS/SPOT 3 – DORIS/TOPEX]
TP-IE-111-4695-ESD	DR10. CAHIER DE RECETTE DORIS/TOPEX MVR1 [DORIS/TOPEX MVR1 ACCEPTANCE FILE]
TP-IE-111-4696-ESD	DR11. CAHIER DE RECETTE DORIS/TOPEX MVR2 [DORIS/TOPEX MVR2 ACCEPTANCE FILE]
TP-IE-111-4697-ESD	DR12. DOSSIER DE RECETTE DORIS/TOPEX [DORIS/TOPEX ACCEPTANCE FILE]
TP-NT-051-7715-JPL	DR13. ANTENNA PHASE CENTRE OFFSETS FOR TOPEX/POSEIDON
TP-NT-41-7070-CN	DR14. LA LOI D'ATTITUDE DE TOPEX (C. VALORGE) [TOPEX ATTITUDE CONTROL LAW (C. VALORGE)]
DS3-IE-11-316-ESD	DR15. DOSSIER DE RECETTE DU MVR DORIS SPOT 3 [ACCEPTANCE FILE FOR THE DORIS SPOT 3 MVR]
DS4-IE-113-7685-SR	DR16. ANTENNE DE BORD DORIS – RAPPORT D'ESSAIS DE MODÈLE DE VOL FM3 /SPOT4 RAPPORT N°2360 [DORIS ONBOARD ANTENNA – TEST REPORTS FOR FM3 /SPOT 4 FLIGHT MODEL, REPORT N°2360]
DS4-PL-D13-OP-9957-SR	DR17. PLAN D'INTERFACE ANTENNE DORIS/SPOT4 [INTERFACE DRAWING FOR DORIS/SPOT 4 ANTENNA]
S4-RD-5037/002/ED	DR18. DOSSIER DE RECETTE DU MVR DORIS/SPOT 4 [ACCEPTANCE FILE FOR MVR DORIS/SPOT 4]
DPP-TR-D11-IE-11326-ESD	DR19. MVR MIQV1 ET FM2 DORIS/ENVISAT – CRE [TEST REVIEW BULLETIN FOR MVR, MIQV1 AND FM2 DORIS/ENVISAT]

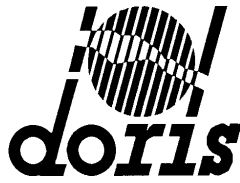
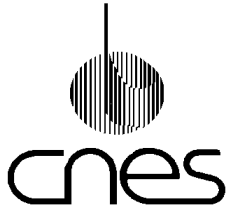

Reference : CO-SP-D0-OP-2460-CN
 Issue : 15.0
 Date : 03/12/04
 Page : 4/38

Title : Modelling of DORIS instruments

DPP-CR-D13-EA-12291-SR	DR20. CRE ANTENNE DORIS FM10 [TEST EVIWE BOARD FOR DORIS MV10 ANTENNA]
DPP-RC-D13-IE-12296-SR	DR21. DCI ANTENNE DORIS MV10 [ICD FOR DORIS FM10 ANTENNA\$S]
89/112-RA/TE/AE/IT/TF	DR22. CALIBRATION ET SUIVI HORAIRE DE LA BALISE MAÎTRESSE DE TOULOUSE DU 25/10/89 [CALIBRATION AND TIME MONITORING OF THE MASTER BEASON AT TOULOUSE ON 25/10/89]
CM-RP-121-2985-SR	DR23. ANTENNES POUR BALISES DE LOCALISATION DORIS TYPE 52290 [ANTENNAS FOR DORIS TYPE 52290 LOCATION BEACONS]
89/CT/DTI/MS/MO/164	DR24. LA FONCTION DE MESURE DATATION DORIS DANS ZOOM : DESCRIPTION [THE DORIS TIME-TAGGING MEASUREMENT FUNCTION IN ZOOM: DESCRIPTION]
CM-NT-D13-EA-9916-SR	DR25. FAX STAREC DU 05/02/93 CENTRES DE PHASE ANTENNES BORD DORIS [STAREC FAX OF 5/2/93, ANTENNA PHASE CENTRES ON DORIS]
CO-SP-D0-OP-14815-CN	DR26. MODELLING OF DORIS 2 GM AND CRYOSAT INSTRUMENTS

LIST OF TBC AND TBD

TBC/TBD	Paragraph	Brief title
TBD	5.1.1.1	Frequency of ground beacon (f_s) f_s (*bal) f_s (IOUS)
TBD	5.3.1	Value of f_b (current and temperature)
TBD	5.3.2.5	Onboard transit time for the time-tagging bit T_{MVR} DORIS/ENVISAT

ABBREVIATIONS

Acronym	Definition
---------	------------

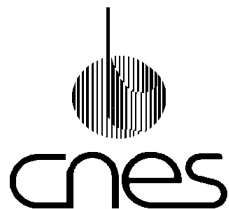

Reference : CO-SP-D0-OP-2460-CN
Issue : 15.0
Date : 03/12/04
Page : 5/38

Title : Modelling of DORIS instruments

BIH	Bureau International de l'Heure [International Time Bureau]
BM	Balise Maître [Master beacon]
BMK	Balise Maître de Kourou [Kourou Master beacon]
BMT	Balise Maître de Toulouse [Toulouse Master Beacon]
CCDP	Centre de Contrôle DORIS POSEIDON [DORIS POSEIDON Control Centre]
CTD	TC de correction de temps directe (décalage du séquençage) [direct time correction TC (shift in sequencing)]
GECO	Groupe d'Exploitation et Coordination des Opérations [Operations Control and Coordination Group]
MVR	Mesure de Vitesse Radiale [Radial Velocity Measurement]
RAZ	TC de remise à zéro de l'heure bord et du séquençage [Reset to zero TC of onboard time and sequencing]
SL	Satellite [Satellite]
TAB	Temps Atomique Balise maître. Selon qu'il s'agit de celle de Toulouse ou de Kourou TAB = TAC ou TAK respectivement [Master Beacon Atomic Time. Depending on whether it is for Toulouse or Kourou TAB = TAC or TAK respectively]
TAC	Temps Atomique CNES (horloge du laboratoire TF qui pilote la BMT) [CNES Atomic Time (clock at the TF laboratory which controls the BMT)]
TAI	Temps Atomique International [International Atomic Time]
TAK	Temps Atomique Kourou (horloge Césium de la BMK) [Kourou Atomic Time (Caesium clock of the BMK)]
TM	TéléMesure [Telemetry]
TOUS	Heure bord DORIS [DORIS onboard time]

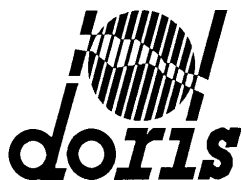

Reference : CO-SP-D0-OP-2460-CN
Issue : 15.0
Date : 03/12/04
Page : 6/38

Title : Modelling of DORIS instruments

CONTENTS

1. SCOPE	7
2. APPLICABILITY	7
3. DESCRIPTION OF MEASUREMENT TYPES	7
4. CONVENTIONS	11
5. MODELS	12
5.1 GROUND	12
5.1.1 BEACONS	12
5.1.2 GROUND ANTENNAS	13
5.1.3 LOSSES DUE TO GROUND CABLES	16
5.2 PROPAGATION (T_p)	16
5.3 ONBOARD INSTRUMENTS	17
5.3.1 ONBOARD USO FREQUENCY	17
5.3.2 MVR	17
5.3.3 ONBOARD ANTENNAS	24
5.3.4 LOSSES DUE TO ONBOARD CABLES	28
5.3.5 PLATFORM GEOMETRY	28

ANNEXE 1 : CONFIGURATION DEPLOYEE DU SATELLITE TOPEX-POSEIDON

ANNEXE 2 : CONFIGURATION DEPLOYEE DU SATELLITE ENVISAT

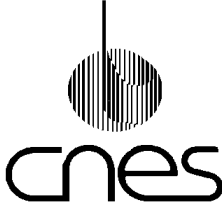
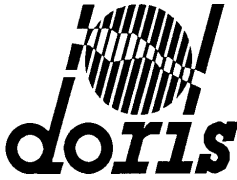
		Reference : CO-SP-D0-OP-2460-CN Issue : 15.0 Date : 03/12/04 Page : 7/38
Title : Modelling of DORIS instruments		

1. SCOPE

This document lists the modelling parameters for DORIS instruments (for all generation beacons + first and second generation onboard instruments) used for DORIS measurements ground processing.

The model is based on a compilation of the definition documents and test results listed in references as well as observations during operations.

NB1: This document does not describe instrument performances.

NB2: The parameters for modelling the DORIS 2GM and Cryosat instruments are described in document DR26.

2. APPLICABILITY

This document applies to operational DORIS/SPOT 2, DORIS/SPOT 3, DORIS/SPOT 4, TOPEX-POSEIDON and DORIS/ENVISAT projects and in particular to ground segments which process the data from these projects.

3. DESCRIPTION OF MEASUREMENT TYPES

There are two types of measurements :

- Doppler measurements (**Figure 1**) which are implemented for each measurement on a beacon,
- Master beacons time-tagging measurements (**Figure 2**), which are used to determine the onboard/ground synchronisation.

NB: Time-tagging on beacons other than master beacons has no effect on final performance which only depends on the restored onboard ground/time correspondence.

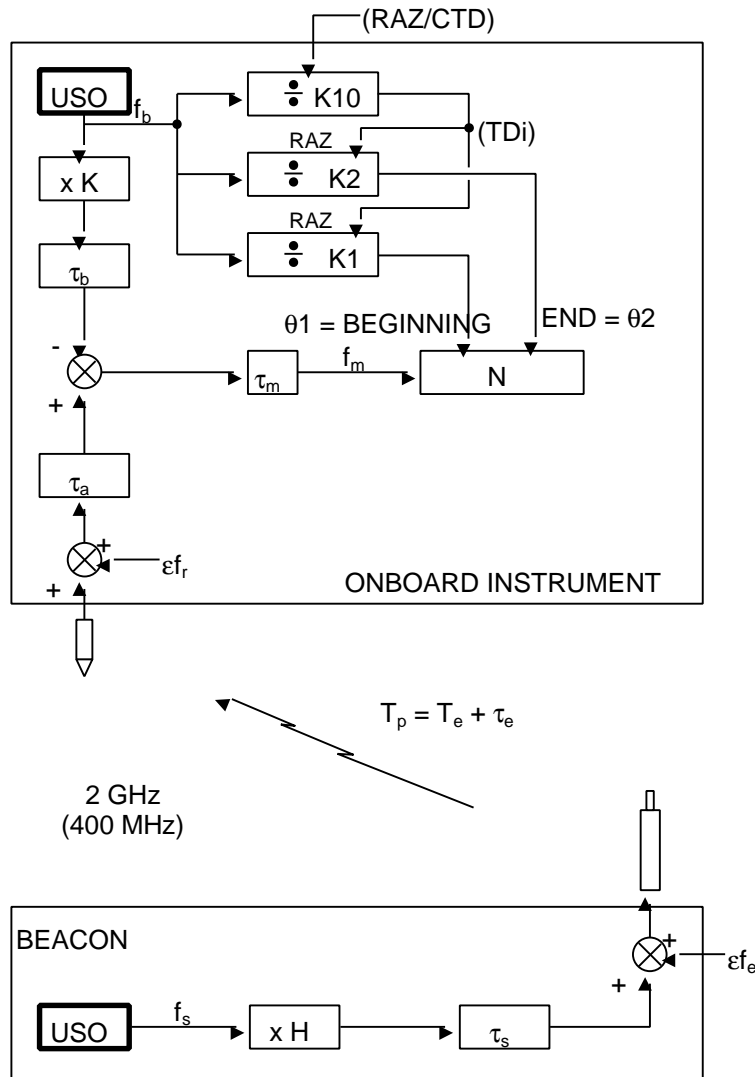
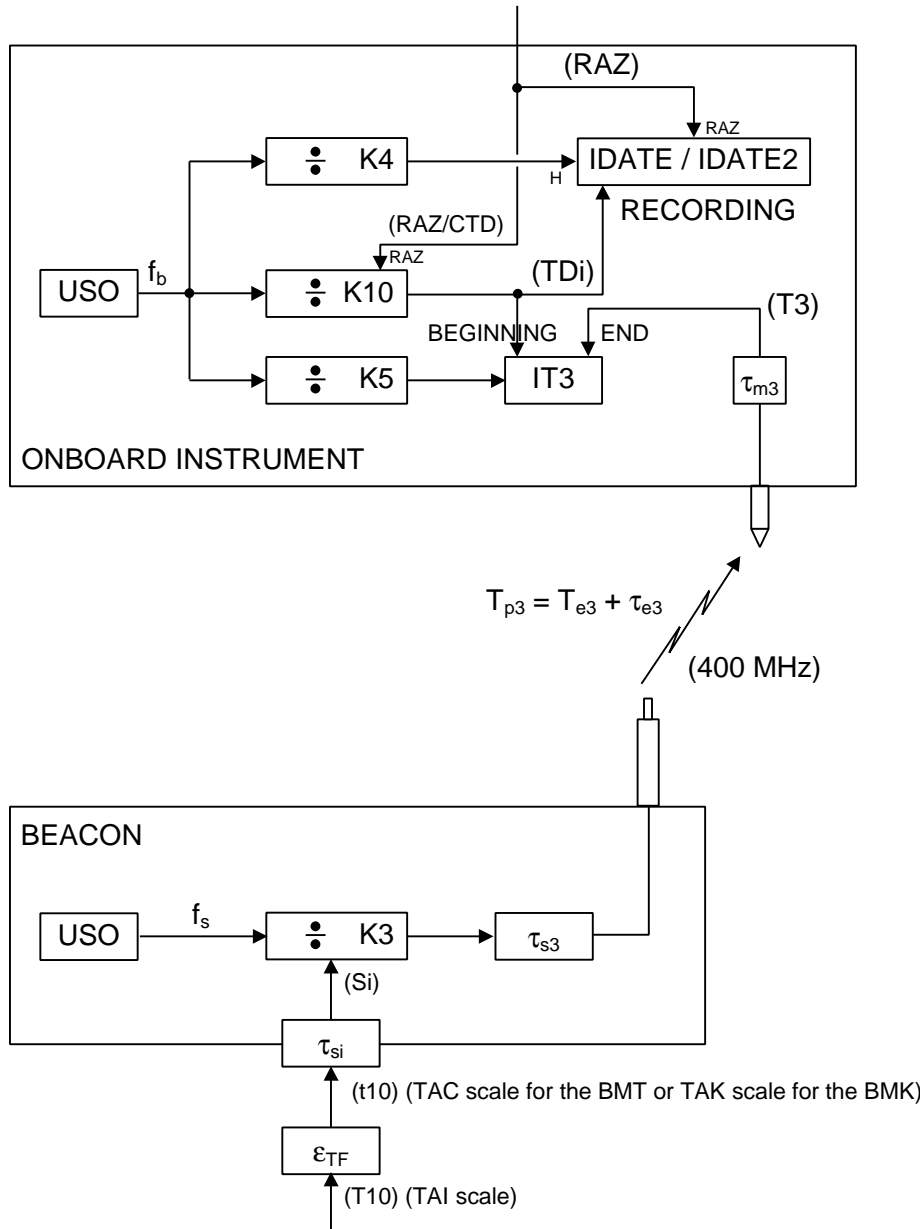

Figure 1: 2 GHz Doppler counting chain
 (400 MHz Doppler counting chain)

Figure 2: Time-tagging chain

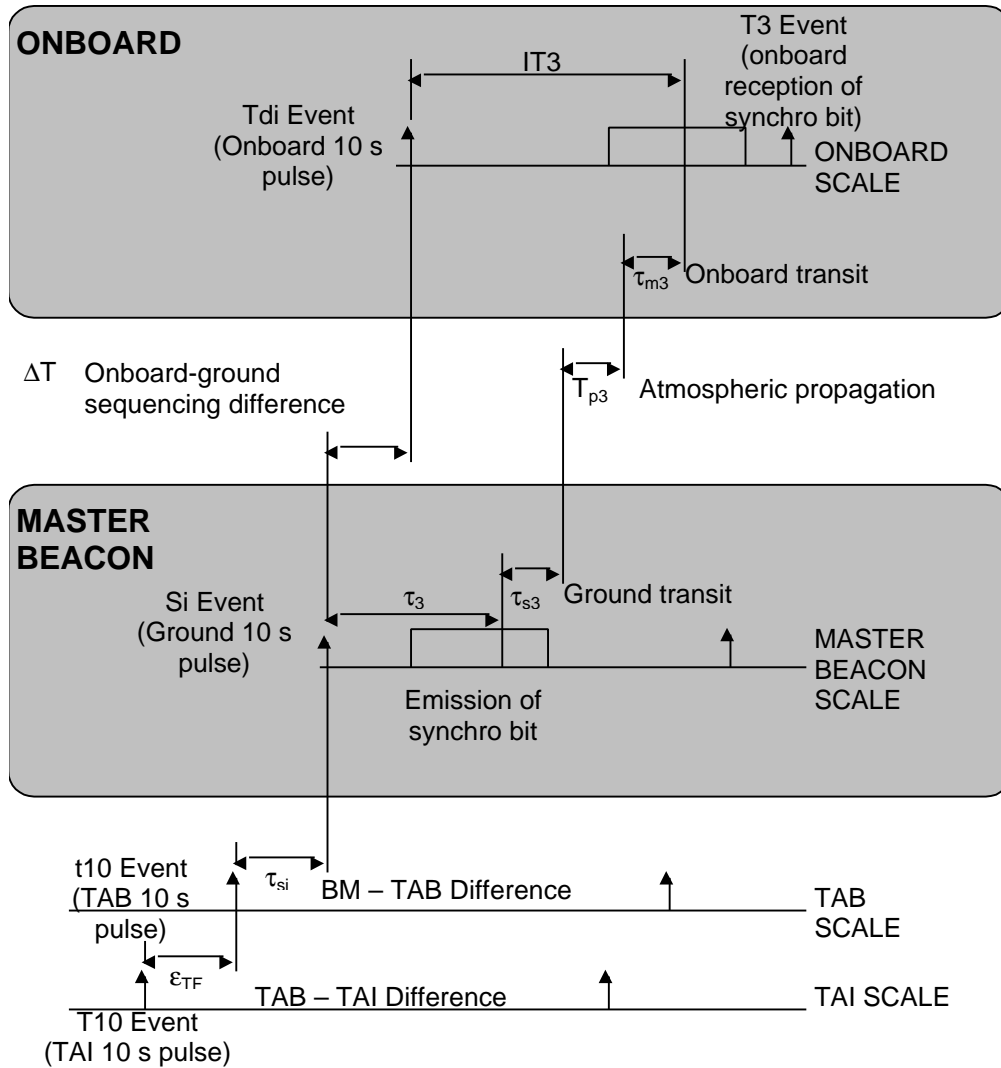
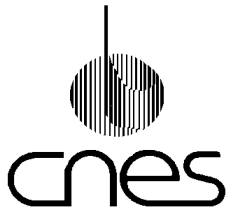

Figure 3: General diagram showing time-tagging measurement (TAB = TAC or TAK)

$\Delta T = 0 \pm 50$ ms on DORIS/SPOT 2

$\Delta T = 1 \text{ s} \pm 50$ ms on DORIS/SPOT 3-SPOT 4 and DORIS/TOPEX

$\Delta T = -1.15 \text{ s} \pm 50$ ms on DORIS/ENVISAT



Reference : CO-SP-D0-OP-2460-CN
 Issue : 15.0
 Date : 03/12/04
 Page : 11/38

Title : Modelling of DORIS instruments

4. CONVENTIONS

Notations are defined below and indexed as follows:

- Index 0: nominal values; indexes completed if necessary by 400 MHz for the 400 MHz channel and 2 GHz for the 2 GHz channel when the values are different.

NOTATIONS

f_s	ground USO frequency (f_{s0} = nominal frequency)
τ_s	ground beacon and antenna electronic delays
f_e	emitted frequency (antenna output)
ϵf_e	noise on emitted frequency
T_p	propagation time between phase centres
T_e	geometric propagation time
τ_e	propagation errors (iono, tropo, antenna patterns)
$f_r, \epsilon f_r$	frequency received and noise on f_r (antenna input)
τ_a	electronic delay on onboard MVR and antenna input
f_b	onboard USO frequency (f_{b0} = nominal frequency)
τ_b	frequency delay for onboard reference ($K \times f_b$)
τ_m	delay on bit frequency
f_m	Doppler counting frequency (f_{m0} with null Doppler)
$\theta 1$	delay in opening the counting window/ TD_i
$\theta 2$	delay in closing the counting window/ TD_i
K1, K2	pulse count for f_b used to generate $\theta 1$ and $\theta 2$
K10	division value of f_b used to make the TD_i
RAZ, CTD	TD_i resynchronisation
N	number of f_m cycles (fraction counting the vernier values at the beginning and end) between $TD_i + \theta 1$ and $TD_i + \theta 2$
K4	value of divider used as a clock for time-tagging the TD_i
K	multiplier of f_b giving onboard reference frequency
K5	divider value acting as clock for time-tagging T_3
H	multiplying coefficient for the beacon USO frequency
TD_i	10 s time pulse for onboard sequencing
T10	10 s TAI integer time pulses
t10	10 s TAC integer time pulses
ϵ_{TF}	TAC – TAI difference
τ_{Si}	delay between Beacon S_i and TAC (delay on T/F lines, room 91 and beacon input electronics)
K3	count f_s used to generate the time-tagging bit
τ_{s3}	ground beacon and antenna electronics delay affecting the time-tagging bit
τ_{m3}	onboard MVR and antenna electronics delay affecting the time-tagging bit
T3	onboard time-tagged event (arrival of time-tagging bit at counter input)
IT3	'Time-tagging' = number of cycles of frequency $f_b/K5$ between TD_i and T3
IDATE	' TD_i onboard time' = count of $f_b/K4$ between the RAZ and the given TD_i (IDATE2 represents the least significant bits of IDATE)
$T_{p3}, T_{e3}, \tau_{e3}$	ditto T_p, T_e, τ_e but for the time-tagging bit

NB: T10, t10, S_i , T3, TD_i , RAZ and CTD are **events** which can be tagged in TAI or onboard time or some other time scale.

Example: TAI (T3) or TOUS (T3) or TAC (TD_i).

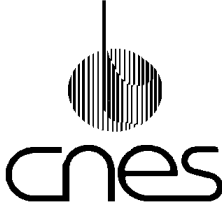
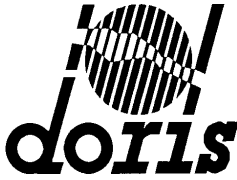
		Reference : CO-SP-D0-OP-2460-CN Issue : 15.0 Date : 03/12/04 Page : 12/38
Title : Modelling of DORIS instruments		

5. MODELS

Depending on the case, delays are represented either by a time or by a phase difference for the given frequency.

5.1 GROUND

5.1.1 BEACONS

5.1.1.1 Ground beacon frequency (F_s)

f_s is identical for both channels. The orbit calculation determines an estimate of f_s per passage. On first generation orbit determination beacons, one can model f_s (T°bal) or f_s (IOUS); with T°bal: beacon temperature and IOUS: data USO current given in the TM (cf DR2) :

- f_s (T°bal) = TBD
- f_s (IOUS) = TBD

$$f_{s0} = 5 \text{ MHz}$$

For the BMs: $f_s = f_{s0}$

$$H_{2\text{GHz}} = 407,25 \text{ and } H_{400\text{MHz}} = 80,25$$

No model $\Rightarrow \tau_s = 0$

5.1.1.2 Beacon times ajustement

ε_{TF} : known *a posteriori*.

This parameter is monitored weekly for each of the master beacons (cf. GECO Report).

τ_{si} = measured on-site during installation. This parameter is also monitored by the GECO which updates it if the installation is modified.

Emission moment of time-tagging bit:

- $K3 = 13.9.10^6$ for the master beacons.
- $K3 = 26.9.10^6$ for the other beacons.

NB: Delay introduced by the K3 count (written D3).

Nominal values:

$$D3_0 = 2.78 \text{ s for the master beacons}$$

$$D3_0 = 5.38 \text{ s for other beacons}$$

$\tau_{s3} = \text{no model} \Rightarrow \tau_{s3} = 0$ for both channels.

τ_{e3} : ditto $\tau_{e 400 \text{ MHz}}$ for the part due to the antenna phase patterns.

5.1.1.3 Ground transit time (t_s)

$\varepsilon_{f_e} = 0$ (no model)

5.1.2 GROUND ANTENNAS

Z is the geocentric-centrifuge axis

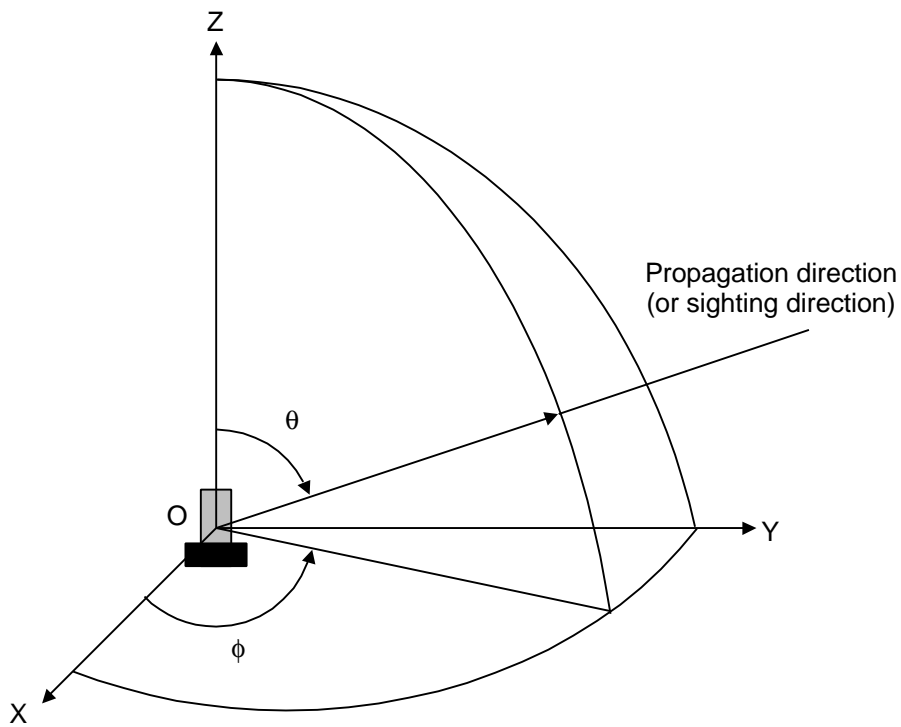

Figure 4: Antennas reference frame
 (O = phase centre)

5.1.2.1 Geometry of ground antennas

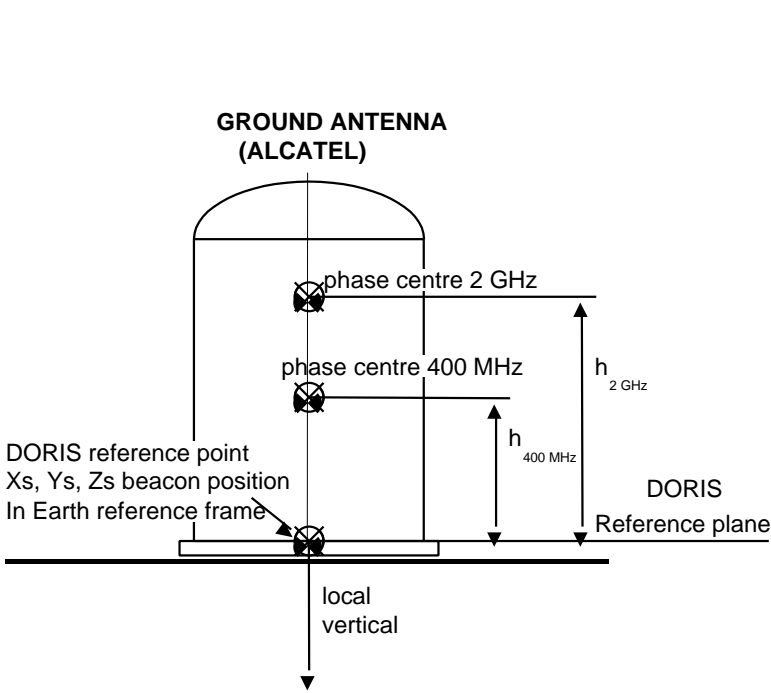

Figure 5

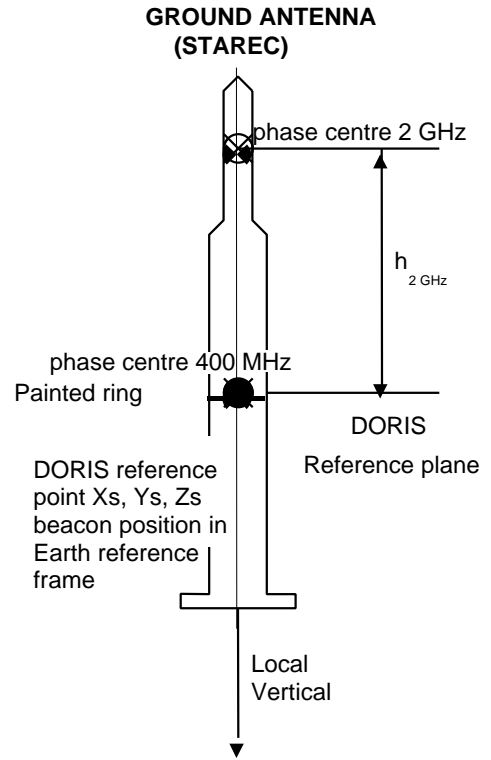
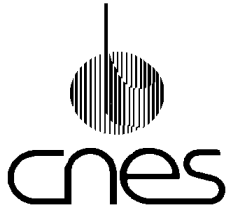

Figure 6

Antenna	ALCATEL	STAREC
h (mm) 2 GHz	510	487
h (mm) 400 MHz	335	0



Reference : CO-SP-D0-OP-2460-CN
Issue : 15.0
Date : 03/12/04
Page : 15/38

Title : Modelling of DORIS instruments

5.1.2.2 Gains

q	ALCATEL (dBi)		STAREC (dBi)	
	401.25 MHz	2036.25 MHz	401.25 MHz	2036.25 MHz
0°	3.2	2.1	3.5	0
10°	3.5	2.6	3.6	0.4
20°	4	2	3.7	0.5
30°	4.4	4	3.8	1.5
40°	4.6	4.4	3.7	3.2
50°	4.2	4.6	3.2	3.9
60°	2.7	2.7	2.5	4
70°	0.6	- 0.1	1	3.2
80°	- 2.7	- 3.3	- 1.3	0.2
90°	- 6	- 7	- 4.2	- 5.6

5.1.2.3 Phase laws

Position of phase centres :

cf. **Figure 5** and **Figure 6** for ground antennas,
cf. **Figure 8** and **Figure 9** for onboard antennas

- ϕ : azimuth phase law

$$\Psi(\phi) = \text{Cte} - \phi$$

- θ : site phase law

$$\Psi(\theta) = \text{Cte} + X(\theta)$$

$\Psi(\theta)$ is known with the precision of $\pm \varepsilon$ taken into account in the medium term error budget (DR5 and DR23).
The values of $X(\theta)$ and ε for the different antennas are given in the following table:

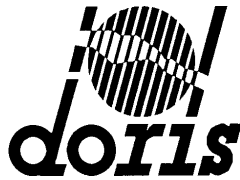
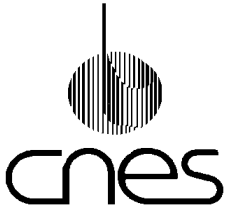

θ (°)	$C(q)$ (°)	Ground antennas			
		Alcatel Type*		Starec Type*	
		2 GHz	400 MHz	2 GHz	400 MHz
0		- 5	0	0	0
10		0	0	0	0
20		10	0	0	0
30		10	0	- 15	0
40		12	0	- 15	0
50		12	0	- 18	0
60		10	0	- 15	0
70		5	0	- 10	0
80		0	0	0	0
90		- 5	0	+ 3	0
ε (°)		2	4	2	4

* The type of antenna is identified by the 4th character of the beacon mnemonic: letter 'A' for the Alcatel type; letter 'B' for the Starec type.

5.1.3 LOSSES DUE TO GROUND CABLES

Channel	Length (m)	Losses (dB)
401.25 MHz	15	- 1.3
2036.25 MHz	15	- 3

5.2 PROPAGATION (T_p)

$$T_p = T_e + \tau_e$$

T_e , τ_e include the combination of ground and onboard antenna phase laws which depend on the propagation direction in the reference frames corresponding to the antennas.

T_e : geometric trajectory time between the 2 phase centres of onboard and ground antennas.

The definition of ϕ and θ is given in **Figure 4**.

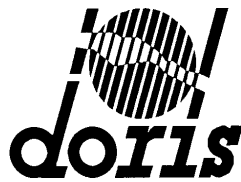

Reference : CO-SP-D0-OP-2460-CN
Issue : 15.0
Date : 03/12/04
Page : 17/38

Title : Modelling of DORIS instruments

5.3 ONBOARD INSTRUMENTS

5.3.1 ONBOARD USO FREQUENCY

The onboard USO frequency f_b is identical for both channels. The orbit calculation determines an estimate of f_b for each pass over a master beacon.

$$f_{b0} = 10 \text{ MHz.}$$

Thermal cycling effect on USO in orbit.

$$\Delta f_b / f_b = A \cos (2\pi t / T_{\text{orbit}} + \psi)$$

with $A = \text{Cte} < 5 \cdot 10^{-12}$ and $\psi = \text{unknown constant}$.

Environment information is in the telemetry (cf. DR2) :

- USO temperature (inaccurate; not permanent on SPOT satellites),
- USO current,
- f_b (current): model TBD,
- f_b (temperature): model TBD.

5.3.2 MVR

5.3.2.1 Doppler measurements at 'central frequency'

- When the 'Doppler frequency' at the MVR level is close to 0, it is difficult to determine the phase of the received signal due to strong perturbation. Measurements, for which the Doppler frequency is close to 0 during counting, have to be eliminated by the ground processing .
- Criteria for elimination which are compatible with the TOPEX/POSEIDON, SPOT4 and CRYOSAT orbits are :
 - **In chained mode:**
 - The **mean** radial velocity of the measurement derived from the 400 MHz or 2 GHz measurement is between **-310 m/sec and + 310 m/sec**
 - or, the measurement **mean** Doppler frequency is between **- 415 Hz and +415 Hz for the 400 MHz channel** or between **- 2105 Hz and +2105 Hz for the 2 GHz channel**
 - or again in terms of cycles, if the **number of cycles measured** is between **1245850 cycles and 1254150 cycles for the 400 MHz channel** or between **1228950 cycles and 1271050 cycles for the 2 GHz channel**
 - **In the unchained mode**
 - the **mean** radial velocity of the measurement derived from the 400 MHz or 2 GHz measurement is between **- 220 m/sec and + 220 m/sec**
 - or the measurement **mean** Doppler frequency is between **- 295 Hz and + 295 Hz for the 400 MHz channel** or between **- 1495 Hz and +1495 Hz for the 2 GHz channel**
 - Or in terms of cycles, if the **number of cycles measured** is between **872935 cycles and 877065 cycles for the 400 MHz channel** or between **864535 cycles and 885465 cycles for the 2 GHz channel**

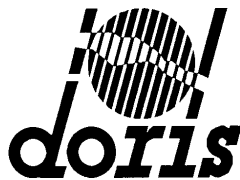
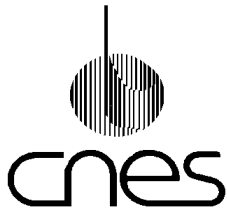

Reference : CO-SP-D0-OP-2460-CN
 Issue : 15.0
 Date : 03/12/04
 Page : 18/38

Title : Modelling of DORIS instruments

5.3.2.2 *Invalidation of incompletely received measurements*

- For strongly time-shifted beacons (and/or for beacons in restart mode RS=1), the Tdi pulse of the 'next' sequence may occur during reception of the modulation.
- When this pulse occurs during the reception of the synchronisation word ("0A6F"H), the on-board software invalidates the IT3 measurement.
- In every other case (Tdi pulse during the reception of the beacon message, or during the reception of the two ICCE words (Error Correcting Code)), the IT3 measurement is performed and the on-board software does not invalidate it : since the message will be incomplete, this kind of measurement should be invalidated by the ground segment.
- Thus it is recommended to invalidate the measurements when :
 - IT3 > 6.5 sec (if the IT3 measurement is done on the 400 MHz channel),
> 6.2 sec (if it is done on the 2 GHz channel)

5.3.2.3 *Onboard Doppler transit time*

- $\tau_a = 0$, $\tau_b = 0$, no model available
- $\varepsilon_{fr} = 0$, no model
- $\tau_m =$ cf. table below:

Transit time (microseconds)	DORIS Instrument						
	SPOT 2	SPOT 3	SPOT 4	ENVISAT 1		ENVISAT 2	
				UT1	UT2	UT1	UT2
τ_{mo} 2 GHz	9	10.2	9,9	49	49	49	49
τ_{mo} 400 MHz	25	26.1	18,8	72	72	72	72

Transit time (microseconds)	TOPEX 1	TOPEX 2
τ_{mo} 2 GHz	10.6	10
τ_{mo} 400 MHz	24.1	24.4

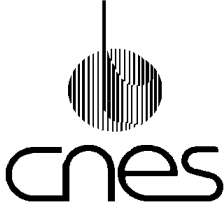
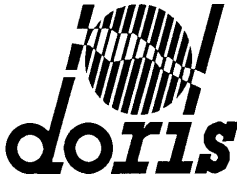
		Reference : CO-SP-D0-OP-2460-CN Issue : 15.0 Date : 03/12/04 Page : 19/38
Title : Modelling of DORIS instruments		

5.3.2.4 Onboard constants

$$K_{10} = 10^8$$

1st generation MVR:

	DORIS/SPOT 2		DORIS/SPOT 3, SPOT 4, TOPEX	
	Chained	Unchained	Chained	Unchained
K1	- 0.15.10 ⁷	+ 0.85.10 ⁷	- 2.15.10 ⁷	+ 0.85.10 ⁷
K2	9.85.10 ⁷	9.85.10 ⁷	7.85.10 ⁷	7.85.10 ⁷

- $K_{2\text{ GHz}} = 203.6125$ $K_{400\text{ MHz}} = 40.1125$
- K1 and K2 are identical for both channels.

2nd generation MVR:

	DORIS/ENVISAT	
	Chained	Unchained
K1	3	3.10 ⁷ +3
K2	10 ⁸ +3	10⁸+3

- $K_{2\text{ GHz}} = 203.6125$ $K_{400\text{ MHz}} = 40.1125$
- K1 and K2 are identical for both channels.

The 300 nanoseconds delay, affecting every opening and closing of the counting window, may be neglected in the processings (300ns = 2mm Along Track)

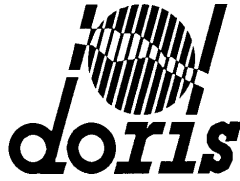
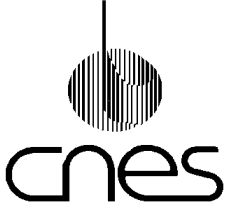

Reference : CO-SP-D0-OP-2460-CN
 Issue : 15.0
 Date : 03/12/04
 Page : 20/38

Title : Modelling of DORIS instruments

5.3.2.5 Onboard transit time for the time-tagging bit

τ_{m3} is a function of the Doppler shift, of the power received and of the MVR temperature:

$$\tau_{m3} = \tau_{m3_0} + \alpha \left(\frac{f_{r_{400\text{ MHz}}} - f_{0_{400\text{ MHz}}}}{f_{0_{400\text{ MHz}}}} \right) + a NR_{400\text{ MHz}}^2 + b NR_{400\text{ MHz}} + c + \beta DT$$

With:

$$f_{0_{400\text{ MHz}}} = 401.25\text{ MHz}$$

$f_{r_{400\text{ MHz}}}$: frequency received on the 400 MHz channel

$NR_{400\text{ MHz}}$: difference between the level received on the 400 MHz channel and the reference level
 $NR = IPR1 + 113\text{ dBm}$

IPR1: power received on the 400 MHz channel in dBm (cf. DR2)

DT: temperature difference with respect to ambient temperature ; $DT = T_{MVR} - 20^\circ\text{C}$

T_{MVR} : temperature of the MVR unit given by telemetry. Taking into account the slight variation of these parameters and sampling on SPOT satellites, a mean value is taken for each satellite.

τ_{m3_0} , α , a , b , c , β are coefficients given in the following table:

Instrument	τ_{m3_0} (μs) (1)	a (s) (4)	a (s/dB ²)	b (s/dB)	c (s)	b ($\mu\text{s}/^\circ\text{C}$) (2)	T_{MVR} ($^\circ\text{C}$) (3)
DORIS/SPOT 2	905	0.28	$+1.486 \cdot 10^{-8}$	$-4.899 \cdot 10^{-7}$	$+9.296 \cdot 10^{-7}$	-0.5	10 (90-95)
DORIS/SPOT 3	875	0.28	$-1.913 \cdot 10^{-8}$	$+3.724 \cdot 10^{-7}$	$+4.603 \cdot 10^{-7}$	-0.5	5 (93-95)
DORIS/SPOT 4	987	0.11	$3.265 \cdot 10^{-9}$	$-37806 \cdot 10^{-10}$	$-1.1395 \cdot 10^{-7}$	+0.15	7 (98)
DORIS/TOPEX MVR 1	941 (5)	0.08	0	$-8.805 \cdot 10^{-9}$	$+5.908 \cdot 10^{-9}$	-0.2	25 (92-95)
DORIS/TOPEX MVR 2	955 (6)	0.04	$-2.47081 \cdot 10^{-9}$	$4.61689 \cdot 10^{-9}$	$4.78832 \cdot 10^{-8}$	$-0.4 \cdot 10^{-6}$	25
DORIS/ENVISAT MVR 1 2 GHz channel	UT1	346 (6)	0	0	0	0	NA
	UT2	340 (6)	0	0	0	0	NA

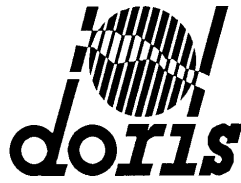
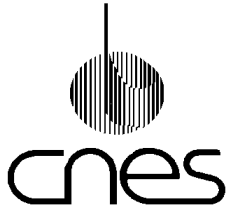

Reference : CO-SP-D0-OP-2460-CN
 Issue : 15.0
 Date : 03/12/04
 Page : 21/38

Title : Modelling of DORIS instruments

Instrument		τ_{m3_0} (μ s) (1)	a (s) (4)	a (s/dB ²)	b (s/dB)	c (s)	b (μ s/ $^{\circ}$ C) (2)	T _{MVR} ($^{\circ}$ C) (3)
DORIS/ENVISAT MVR 1, 400 MHz channel	UT1	863 (6)	0	0	0	0	0	NA
	UT2	893 (6)	0	0	0	0	0	NA
DORIS/ENVISAT MVR 2, 2 GHz channel	UT1	332 (6)	0	0	0	0	0	NA
	UT2	336 (6)	0	0	0	0	0	NA
DORIS/ENVISAT MVR 2, 400 MHz channel	UT1	871 (6)	0	0	0	0	0	NA
	UT2	878 (6)	0	0	0	0	0	NA

NB:

- (1) τ_{m3_0} is the vacuum transit time, at f_0 , at the reference reception level (- 113 dBm), at 20°C. The long-term error in this parameter may be several microseconds and an external calibration device must be used (laser for instance) in order to achieve very accurate time-tagging ($\approx 1 \mu$ s).
- (2) Valid in the range from 0 to 25°C.
Mean value observed.
- (3) Given for information. Mean value observed in flight.
- (4) At the "central frequency" (null Doppler) an aberrant time-tag (with an error of a few tens of microseconds) may occur.
- (5) Manufacturer's data = 947, laser calibration = 941.
- (6) Manufacturer's data.

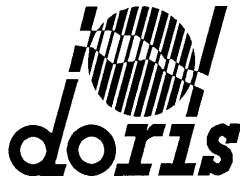
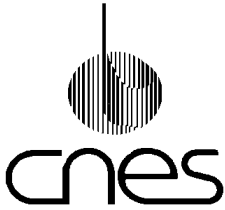

5.3.2.6 Onboard time-tagging

- **1st generation and 2nd generation instruments:** (SPOT 2, SPOT 3, SPOT 4, TOPEX and ENVISAT)

The time T3 at which the time-tagging bit arrives and is received onboard is tagged by a counter as IT3. The value of IT3 is determined between TD_i and the descending edge of the last bit of the synchronisation word.

$$IT3 = 1/K5 \int_{TD_i}^{T3} f_b(t) dt$$

with time (TD_i) < time (T3) < time (TD_i) + 10 s

K4 = 10⁵
 K5 = 10

Ditto for both channels

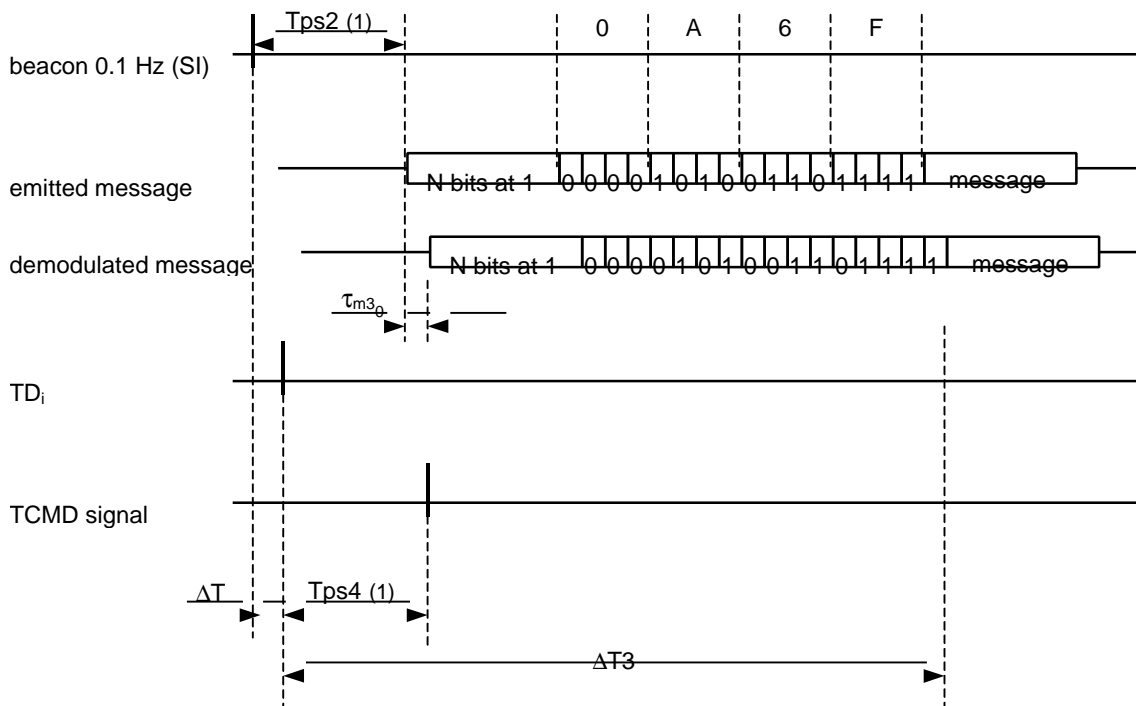

(1) Constructor convention

Tps2 = 2.1 s for a master beacon, with N=120
 4.9 s for the other first and second generation beacons with N=80
 4.7 s for the other third generation beacons with N=120

Tps4 = difference between the TD_i pulse and the TCMD pulse = 3.10⁷/ FOUS = 3 s nominally

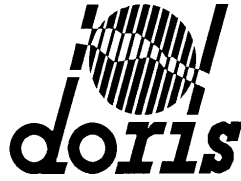
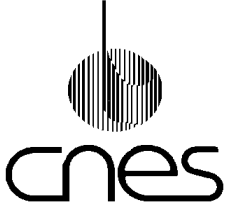

5.3.2.7 Cycle counting

- **1st generation and 2nd generation instruments:** (SPOT 2, SPOT 3, SPOT 4, TOPEX and ENVISAT)

$N_{2\text{ GHz}}$ is downloaded in the TM in the form of 3 counters: IT12, IN2GHZ and IT22 (resp. IT14, IN4MHZ and IT24 for $N_{400\text{ MHz}}$) (DR2).

The IT12, IT22, IT14 and IT24 counters are incremented at the frequency f_b , the IN4MHZ and N2GHZ counters are incremented at frequencies $f_{m_{400\text{ MHz}}}$ and $f_{m_{2\text{ GHz}}}$.

If we write:

$$V_{1_{2\text{ GHz}}} = (\text{IT12}) / [f_b (\text{TD}_i + \theta_1)]$$

$$V_{2_{2\text{ GHz}}} = (\text{IT22}) / [f_b (\text{TD}_i + \theta_2)]$$

$$V_{1_{400\text{ MHz}}} = (\text{IT14}) / [f_b (\text{TD}_i + \theta_1)]$$

$$V_{2_{400\text{ MHz}}} = (\text{IT24}) / [f_b (\text{TD}_i + \theta_2)]$$

We then get:

- $N_{2\text{ GHz}} = \text{IN2GHZ} + v_{1_{2\text{ GHz}}} f_{m_{2\text{ GHz}}} (\text{TD}_i + \theta_1) - v_{2_{2\text{ GHz}}} f_{m_{2\text{ GHz}}} (\text{TD}_i + \theta_2)$, and
- $N_{400\text{ MHz}} = \text{IN4GHZ} + v_{1_{400\text{ MHz}}} f_{m_{400\text{ MHz}}} (\text{TD}_i + \theta_1) - v_{2_{400\text{ MHz}}} f_{m_{400\text{ MHz}}} (\text{TD}_i + \theta_2)$

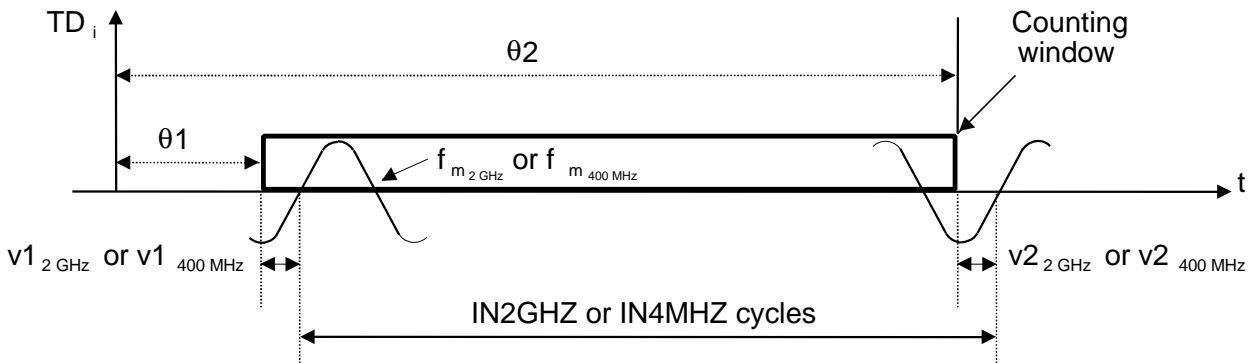

5.3.3 ONBOARD ANTENNAS

Z is the geocentric-centripetal axis

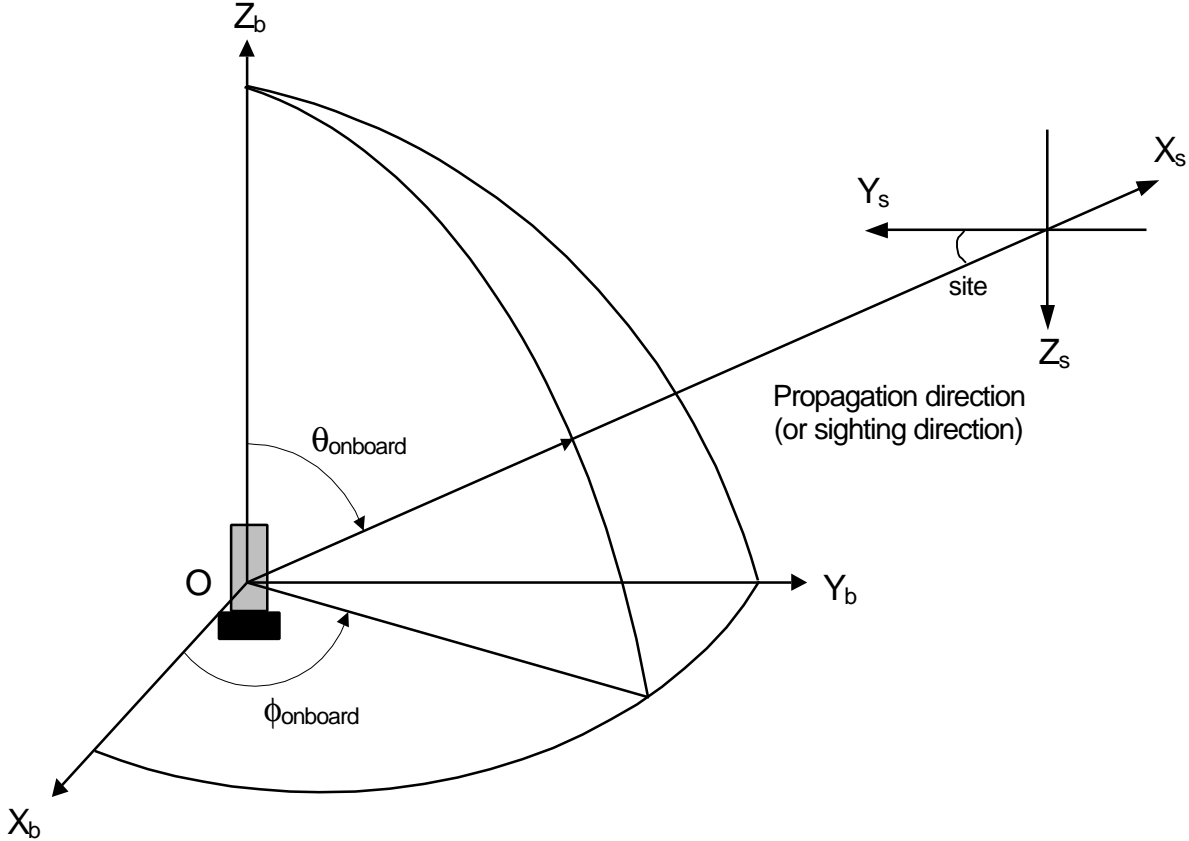

Figure 2: Antennas reference frame
 (O = phase centre)

The site and $\theta_{onboard}$ angles are linked by the formula:

$$q_{onboard} = \text{Arc sin} \left(R \frac{\cos(\text{Site})}{(R + h)} \right)$$

in which R = the Earth radius = 6378 (km)

h = the satellite altitude (km)

5.3.3.1 Onboard antenna geometry

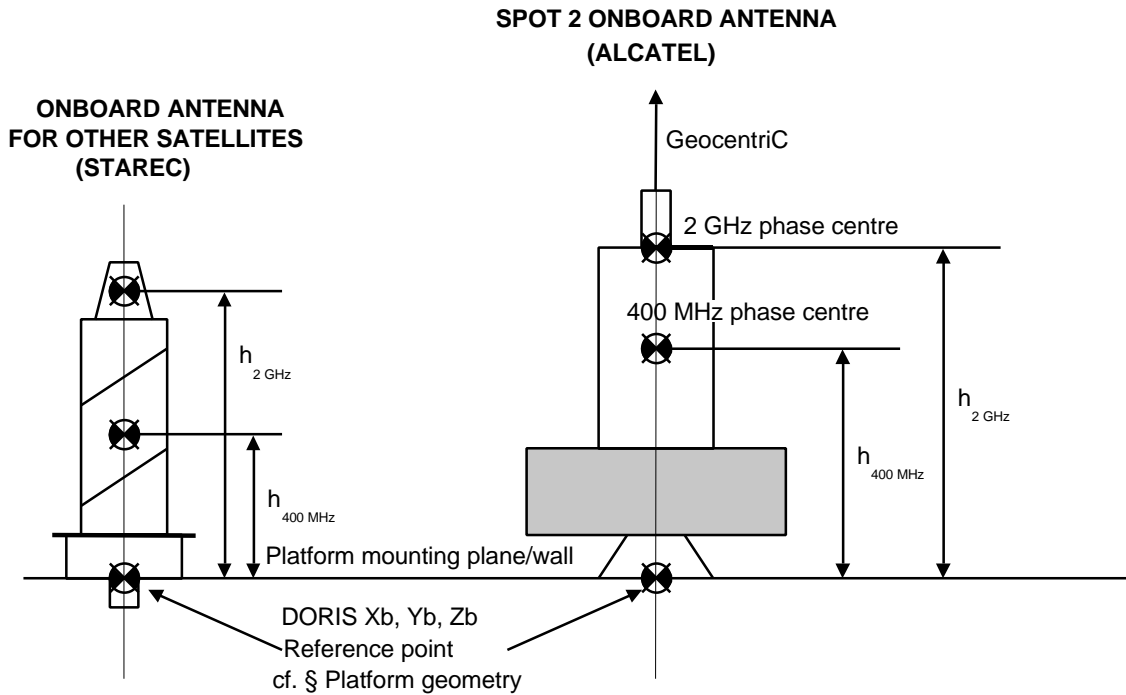
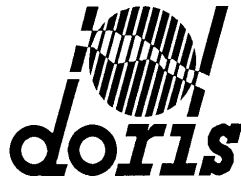
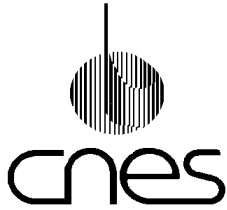

Figure 8

Figure 9

Antenna	SPOT 2 onboard ALCATEL type	SPOT 3 onboard STAREC type	SPOT 4 onboard STAREC type	TOPEX onboard STAREC type	ENVISAT onboard FM STAREC type
h (mm) 2 GHz	355	315	316	317	318
h (mm) 400 MHz	160	152	155	161	153



Reference : CO-SP-D0-OP-2460-CN
 Issue : 15.0
 Date : 03/12/04
 Page : 26/38

Title : Modelling of DORIS instruments

5.3.3.2 Gains

Site (°)	φ_{onboard} (°)	SPOT 2		SPOT 3		SPOT 4		ENVISAT	
		400	2 G	400	2 G	400	2 G	400	2 G
90	0	5.2	4.9	6	4.2	5.25	4.2	5	4
80	8.83	4.4	4.9	6	4.2	5.25	4.2	4.9	4
70	17.61	3.7	5.3	6	4.2	5.25	4.2	4.8	3.8
60	26.25	3.2	4.4	5,5	3.7	4.75	3.7	40.4	3.3
50	34.65	2.5	3.6	5	3.4	4.25	3.1	3.8	2.6
40	42.66	1.7	2.4	4.2	2.7	3.25	2.2	3	2.2
30	50	1.1	0.6	2.8	2.2	2,5	1.7	2.2	1.6
20	56.23	0.7	0.2	2.3	1.7	1.75	0.8	0.8	1
10	60.6	0.1	-1	1.7	1.2	1	0.3	0	0.6
0	62.2	-1	-2	1.5	0.7	0.5	-0.2	-0.3	0.4

Site (°)	φ_{onboard} (°)	TOPEX	
		400	2 G
90	0	5	4
80	8.24	5	4
70	16.4	5	4
60	24.37	4.5	3.7
50	32.04	4	3.25
40	39.21	3.5	2.75
30	45.62	2.6	2.25
20	50.85	2	1.75
10	54.37	1.5	1.5
0	55.62	1	1.25

5.3.3.3 Phase laws

- ϕ_{onboard} : azimuth phase law, : $\psi(\phi_{\text{onboard}}) = \text{cte} - \phi_{\text{onboard}} \pm \varepsilon$, in which ε is given by the following table :

	SPOT 2		SPOT 3		SPOT 4		ENVISAT	
	2 G	400	2 G	400	2 G	400	2 G	400
ε°	2	4	1.9	1.4	2	2	1.9	1.4

	TOPEX	
	2 G	400
ε°	1.9	1.4

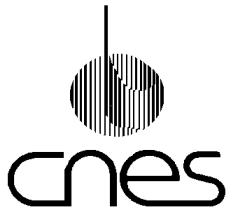

Reference : CO-SP-D0-OP-2460-CN
 Issue : 15.0
 Date : 03/12/04
 Page : 27/38

Title : Modelling of DORIS instruments

- θ_{onboard} : site phase law, : $\psi(\theta_{\text{onboard}}) = \text{cte} + X(\theta_{\text{onboard}})$.
 $\psi(\theta_{\text{onboard}})$ is known with an accuracy of $\pm \varepsilon$ taking into account the medium term error budget (DR5 et DR9). The values of $X(\theta)$ and ε for the different antennas are given in the following table.

C (f_{onboard}) $\theta_{\text{bord}} (^{\circ})$	SPOT 2		SPOT 3		SPOT 4		ENVISAT	
	2 G	400	2 G	400	2 G	400	2 G	400
0	5	7	0	0	0	0	0	0
10	6	6	0	0	0	0	0	0
20	7	5	0	0	0	0	0	0
30	9	3	0	0	0	0	0	0
40	8	0	0	0	0	0	0	0
50	0	-2	0	0	0	0	0	0
60	-6	-6	0	0	0	0	0	0
70								
80								
90								
$\varepsilon (^{\circ})$	2	4	1.9	1.4	2	2	1.9	1.4

C (f_{onboard}) $\theta_{\text{bord}} (^{\circ})$	TOPEX	
	2 G	400
0	0	0
10	0	0
20	0	0
30	0	0
40	0	0
50	0	0
60	0	0
70	0	0
80	0	0
90	0	0
$\varepsilon (^{\circ})$	1.9	1.4

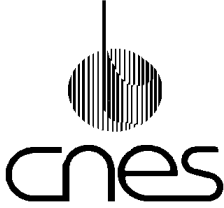
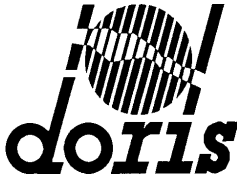
		Reference : CO-SP-D0-OP-2460-CN Issue : 15.0 Date : 03/12/04 Page : 28/38
Title : Modelling of DORIS instruments		

5.3.4 LOSSES DUE TO ONBOARD CABLES

These are cables linking the antenna to the MVR.

	SPOT 2	SPOT 3	SPOT 4	ENVISAT	
				MVR1	MVR2
400 MHz channel	- 0.85 dB	- 0.8 dB	- 0.75 dB	- 0.98 dB	- 0.89 dB
2 GHz channel	- 1.8 dB	- 2.075 dB	- 1.72 dB	- 2.46 dB	- 2.03 dB

	TOPEX
400 MHz channel	- 0.56 dB
2 GHz channel	- 1.32 dB

5.3.5 PLATFORM GEOMETRY

NB:

- (1) The mass and the position of the centre of gravity may evolve during orbit life. These parameters must be monitored during operations. Given the very slow evolution, it is sufficient to record them after each big manoeuvre.

Comments:

- (1) Thermal cycling in orbit creates a sinusoidal phase variation which mainly affects the multiplication chain. This effect has an impact on the Doppler measurement similar to the USO thermal cycling effect (cf. § onboard USO frequency) but remains much lower than the latter.
- (2) The two local orbital reference frames which are currently used are called P, R, Y (Pitch, Roll, Yaw), and R, N, T (Radial, Tangential, Normal). They correspond as follows:
 - Pitch = - Normal,
 - Roll = Tangential,
 - Yaw = Radial.

5.3.5.1 SPOT Satellites

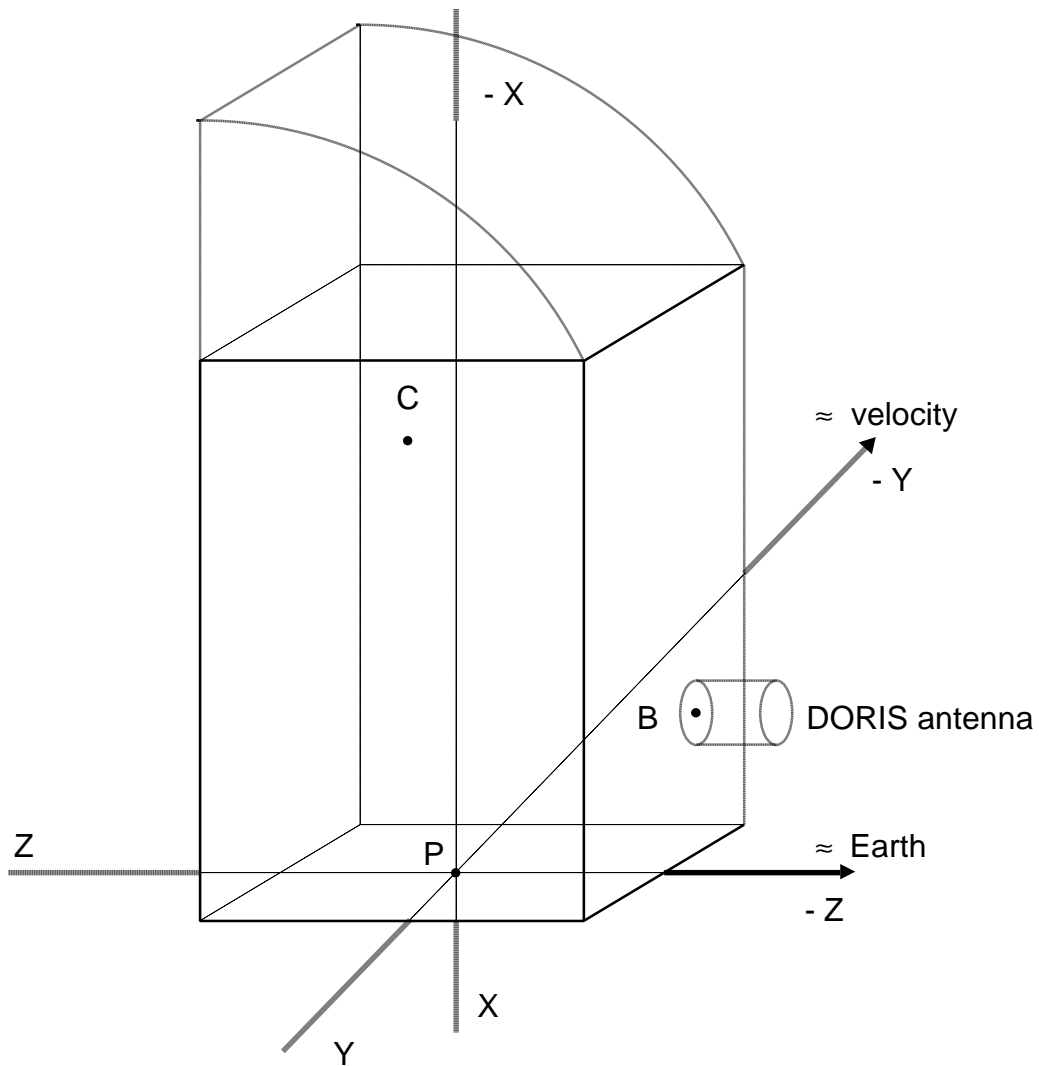
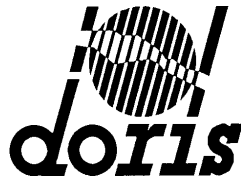
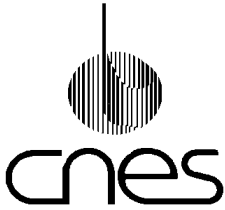

Figure 3: Position of DORIS antenna on SPOT satellites

- C : satellite centre of gravity
- B : DORIS antenna reference point
- P : satellite mounting plane centre

NB:

There is a small rotation (bias) between the X, Y, Z reference frame and the x, y, z reference frame (x: perpendicular to the orbital plane; - z: geocentric). Rotation matrix: TBD.



Reference : CO-SP-D0-OP-2460-CN
 Issue : 15.0
 Date : 03/12/04
 Page : 30/38

Title : Modelling of DORIS instruments

Satellite	SPOT 2	SPOT 3	SPOT 4
xB (m)	- 0.770	- 0.770	- 0.770
yB (m)	- 0.330	- 0.330	- 0.330
zB (m)	- 0.950	- 0.950	- 0.950
xC (m) (1)	- 1.612	- 1.584	- 1.901
yC (m) (1)	+ 0.009	- 0.002	+ 0.008
zC (m) (1)	+ 0.025	+ 0.023	+ 0.059
Satellite mass (on orbit) (1)	1827.5 (2)	1875.2 (3)	2738 (4)

NB:

- (1) This value evolves over time
- (2) Value after manoeuver 18/09/96.
- (3) Value after manoeuver 10/09/96.
- (4) Value since 01/04/98 after station positioning .

The components of the centre of gravity - 2 GHz phase centre vector in a platform reference frame are thus (approximately):

Satellite	SPOT 2	SPOT 3	SPOT 4
X (m)	0.842	0.814	1.131
Y (m)	- 0.339	- 0.328	- 0.338
Z (m)	- 1.330	- 1.288	- 1.325

With:

- $X (m) = xB (m) - xC (m)$
- $Y (m) = yB (m) - yC (m)$
- $Z (m) = zB (m) - zC (m) - h_{2\text{GHz}} (m)$

The nominal attitude is geocentric. The pitch axis is - X, the roll axis is - Y, the yaw axis is + Z.

When all of the angles (roll, pitch, yaw) are null, the transition matrix between the platform reference frame and the local orbital reference frame T, R, L is thus:

$$\begin{pmatrix} X_{ol} \\ Y_{ol} \\ Z_{ol} \end{pmatrix} = \begin{pmatrix} -1.0 & 0.0 & 0.0 \\ 0.0 & -1.0 & 0.0 \\ 0.0 & 0.0 & 1.0 \end{pmatrix} \begin{pmatrix} X_{pf} \\ Y_{pf} \\ Z_{pf} \end{pmatrix}$$

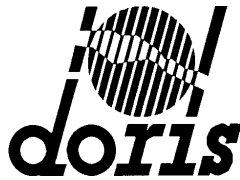

Reference : CO-SP-D0-OP-2460-CN
Issue : 15.0
Date : 03/12/04
Page : 31/38

Title : Modelling of DORIS instruments

5.3.5.2 ENVISAT Satellite

The description of the platform reference frame is given in **Annex2**.

Satellite	ENVISAT 1
xB (m)	- 7.052
yB (m)	- 1.085
zB (m)	- 1.407
xC (m) (1)	-4.365
yC (m) (1)	-0.002
zC (m) (1)	-0.039
Satellite mass (on orbit) (1)	8106.4

(1) This value evolves over time

xB, yB and zB read on the ENVISAT DCI and on the MV10 Antenna DCI. xC, yC and zC given by the ESOC 'flight dynamics files / SSALTO' on 11/3/2002.

The components of the centre of gravity - 2 GHz phase centre vector in the platform reference frame are thus (approximately):

Satellite	ENVISAT 1
X (m)	-2.687
Y (m)	-1.083
Z (m)	-1.686

With:

- $X (m) = xB (m) - xC (m)$
- $Y (m) = yB (m) - yC (m)$
- $Z (m) = zB (m) - zC (m) - h_{2\text{GHz}} (m)$

The nominal attitude is for yaw control around the main satellite viewing axis (maintained according to the normal to the ellipsoid by piloting in roll and pitch). The pitch axis is - X, the roll axis is - Y, the yaw axis is + Z.

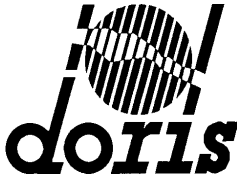
		Reference : CO-SP-D0-OP-2460-CN Issue : 15.0 Date : 03/12/04 Page : 32/38
Title : Modelling of DORIS instruments		

When all of the angles (roll, pitch yaw) are null, the transition matrix for switching from the platform reference frame to the local orbital reference frame T, R, L is thus:

$$\begin{pmatrix} X_{ol} \\ Y_{ol} \\ Z_{ol} \end{pmatrix} = \begin{pmatrix} -1.0 & 0.0 & 0.0 \\ 0.0 & -1.0 & 0.0 \\ 0.0 & 0.0 & 1.0 \end{pmatrix} \begin{pmatrix} X_{pf} \\ Y_{pf} \\ Z_{pf} \end{pmatrix}$$

5.3.5.3 TOPEX Satellite

The deployed configuration of the TOPEX-POSEIDON satellite is given in **Annex1**

Satellite	TOPEX
xB (m)	0.0921
yB (m)	1.0922
zB (m)	0.8647
xC (m) (1)	0.165
yC (m) (1)	- 0.419
zC (m) (1)	0.051
Satellite mass (on orbit) (1)	2406.4 (2)

(1) This value evolves over time

(2) Value known on 2/7/96.

The components of the centre of gravity - 2 GHz phase centre vector in the platform reference frame are thus (approximately):

Satellite	TOPEX
X (m)	- 0.0729
Y (m)	1.5112
Z (m)	1.1307

The nominal attitude is complex (involving yaw-steering, fixed law, pitch piloting). We may refer to the excellent DR25 document. In one of the fixed laws (when the yaw angle is null and + X has the same direction as the velocity), the pitch axis is + Y, the roll axis is + X and the yaw axis is - Z.

When all of the angles (roll, pitch, yaw) are null, the transition matrix for switching from the platform reference frame to the local orbital reference frame T, R, L is thus:

$$\begin{pmatrix} X_{ol} \\ Y_{ol} \\ Z_{ol} \end{pmatrix} = \begin{pmatrix} 0.0 & 1.0 & 0.0 \\ 1.0 & 0.0 & 0.0 \\ 0.0 & 0.0 & -1.0 \end{pmatrix} \begin{pmatrix} X_{pf} \\ Y_{pf} \\ Z_{pf} \end{pmatrix}$$

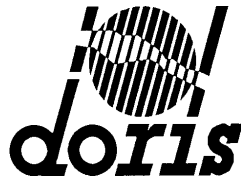
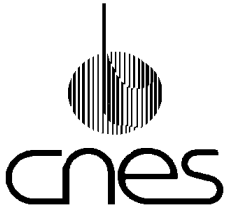

Reference : CO-SP-D0-OP-2460-CN
Issue : 15.0
Date : 03/12/04
Page : 33/38

Title : Modelling of DORIS instruments

ANNEX 1 : DEPLOYED CONFIGURATION OF TOPEX-POSEIDON SATELLITE

Title : Modelling of DORIS instruments

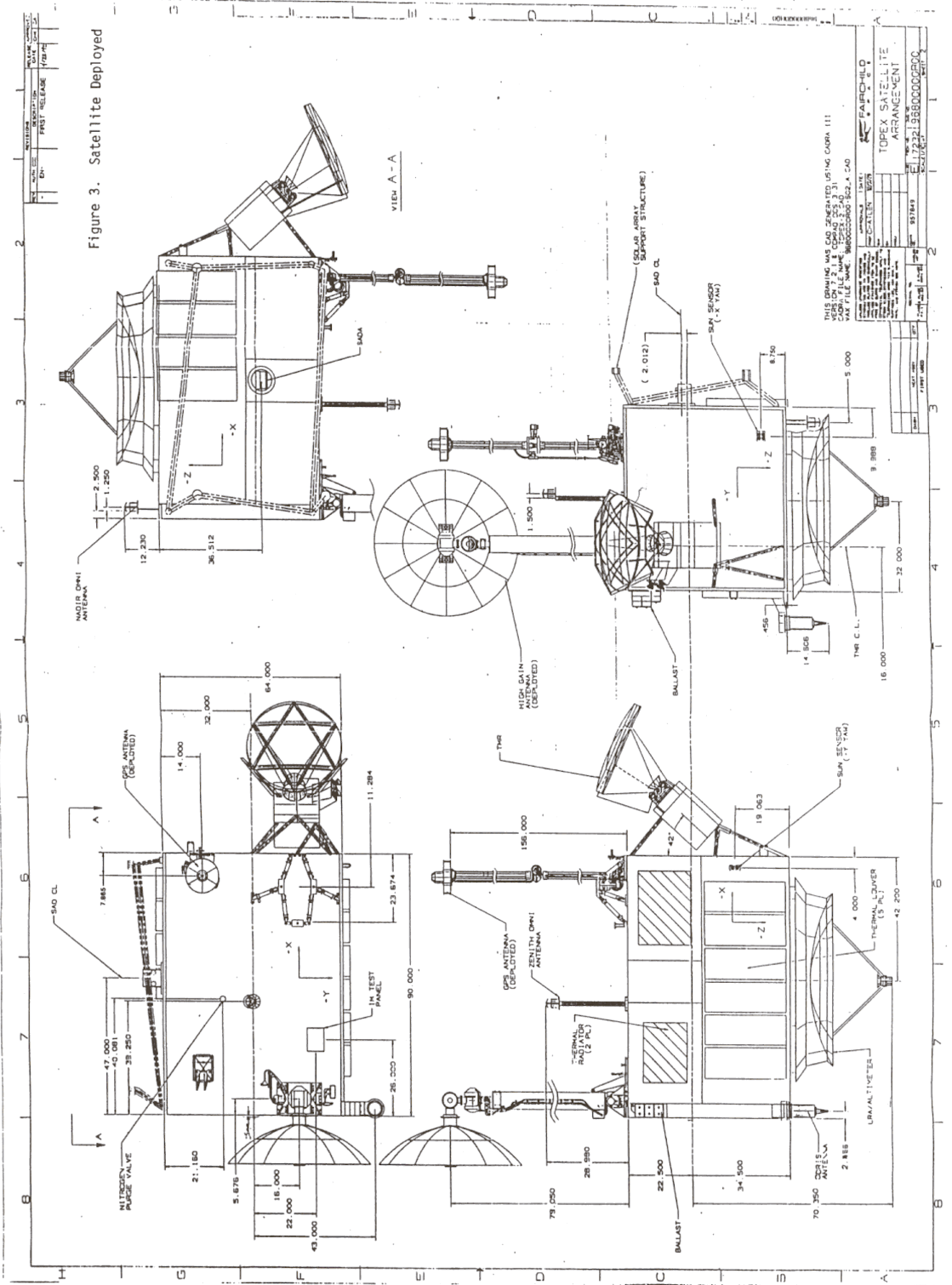

ANNEX 2 : DEPLOYED CONFIGURATION OF THE ENVISAT SATELLITE

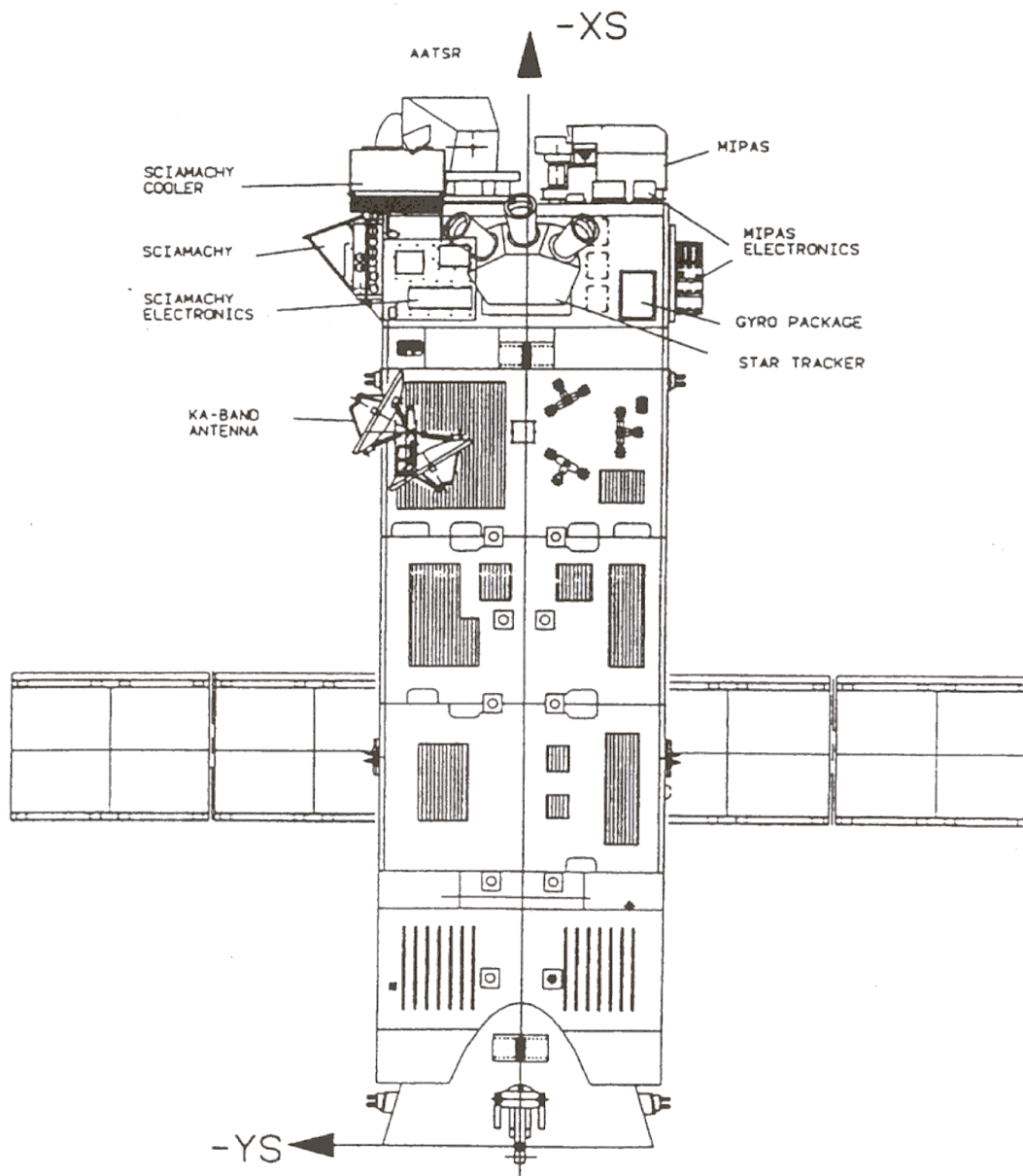
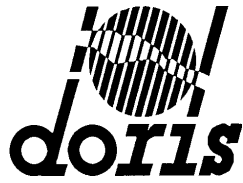
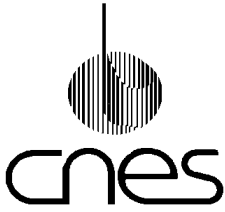

Figure 4: ENVISAT-1 (rear view)



Reference : CO-SP-D0-OP-2460-CN
Issue : 15.0
Date : 03/12/04
Page : 36/38

Title : Modelling of DORIS instruments

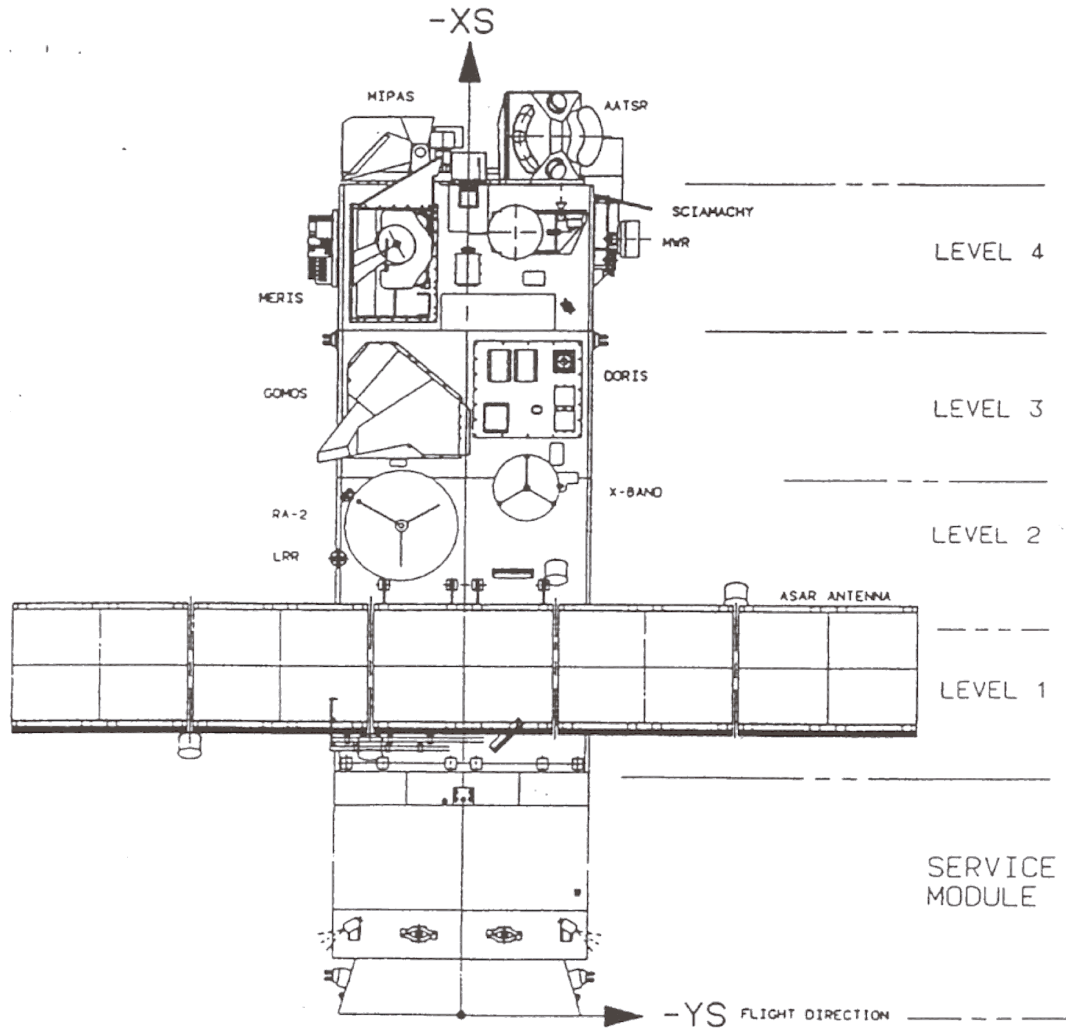

Figure 5: ENVISAT-1 (front view)

Title : Modelling of DORIS instruments

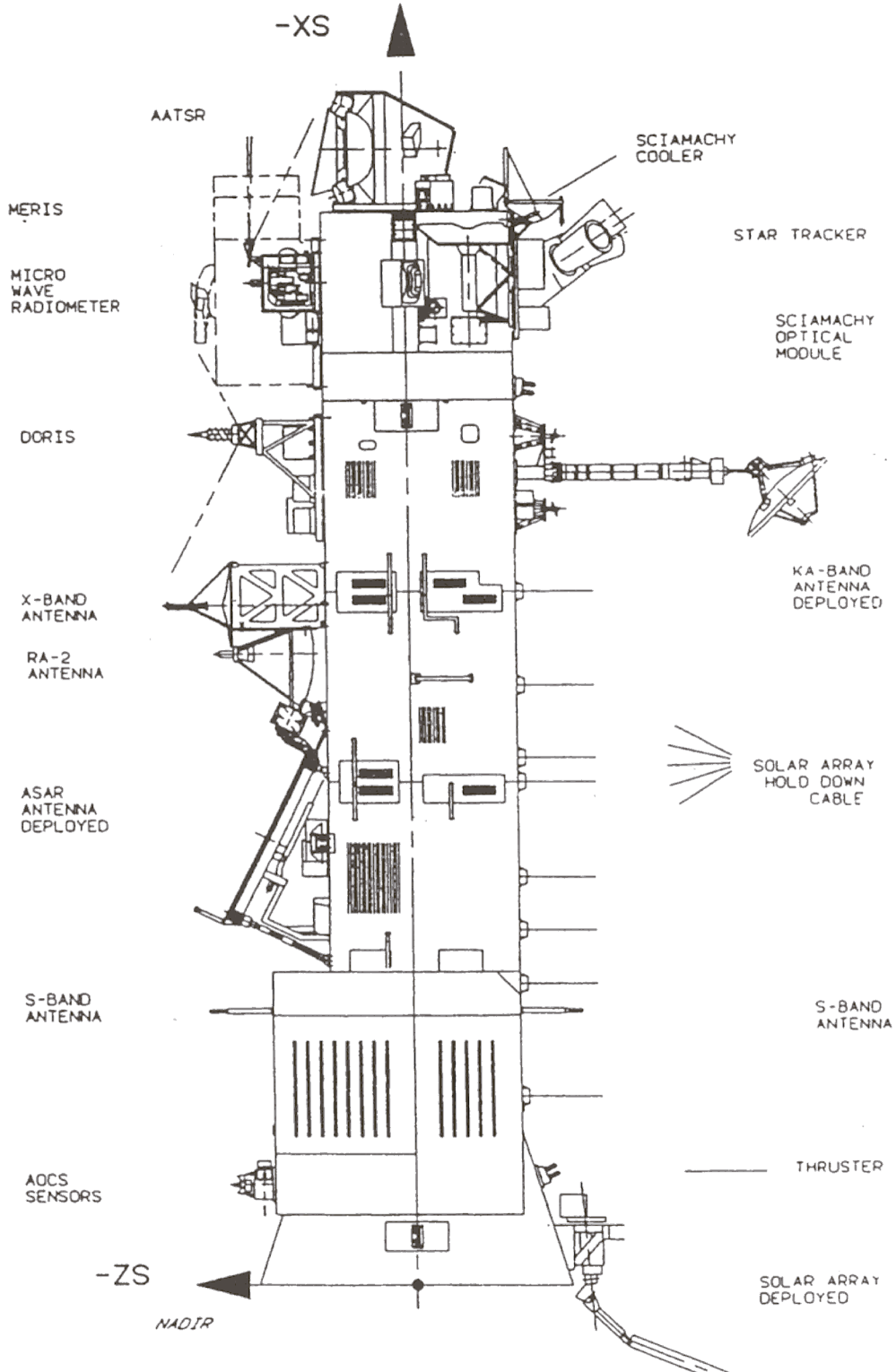
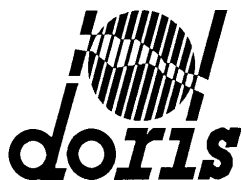

Figure 6: ENVISAT-1 (side view)



Reference : CO-SP-D0-OP-2460-CN
 Issue : 15.0
 Date : 03/12/04
 Page : 38/38

Title : Modelling of DORIS instruments

DISTRIBUTION

CNES Distribution:

			document	1 st page
P. ESCUDIER		BP 2002	X	
J. PERBOS		'		X
A. AURIOL		'	X	
C. JAYLES		'	X	
P. PACHOLCZYK		'	X	
P. SENGENES		'	X	
I. FRATTER		'	X	
M. VIVIES		'		X
S. COUTIN-FAYE		'	X	
N. MALECHAUX		'	X	
J. NOUBEL		'	X	
G. TAVERNIER		'	X	
JP. GRANIER		'	X	
P. VINCENT		'		
N. PICOT		'		X
DORIS documentation		'	X	
SALP documentation		'	X	
JM. LOPEZ		BP 2012		
C. JOUVE		'	X	
M. BRUNET		'		
JF. DUTREY		'		
JL. ISSLER		'		
P. CHADOUTAUD		BP 1413		
G. KEIL		BP 1415		X
F. MERCIER		BP 1214	X	
S. HOURY		'	X	
P. BOUDOU		BP 1501		X
L. CLARAC		'	X	
MH. GOMEZ		BP 1502		

External distribution:

			document	1 st page
M. BOUCHET	THALES AIRBORNE SYSTEMS		X	
H. FAGARD	IGN		X	
F. ROZO	COFRAMI			
P. THEBAULT	DACTEM			
M. MIDROIT	SMP			
M. DESTOUESSE	CLS		X BE exploitation	